

# Exhibitor Service Manual

## **UNIVERSITY OF HOUSTON ROCKWELL CENTER CAREER FAIR**

September 25, 2015

University of Houston Hilton Hotel  
Conrad, Shamrock, Waldorf Ballroom

Houston, TX

# FREEMAN

## SERVICE INFORMATION

### BOOTH EQUIPMENT

Each 8' x 8' booth will be set with 8' red and white back drape, 3' high red side drape, 1 - 6' x 30" red draped table, 2 - Limerick side chairs, 1 - corrugated wastebasket and a 7" x 44" one-line identification sign. By order of the Fire Marshal, **NOTHING MAY BE ATTACHED TO THIS DRAPE. PLEASE NOTE: THERE ARE NO SUBSTITUTIONS ALLOWED.**

### EXHIBIT HALL CARPET

The exhibit area is carpeted.

### DISCOUNT PRICE DEADLINE DATE

**Order early to take advantage of advance order discount rates. Place your order by September 16, 2015.**

## SHOW SCHEDULE

### EXHIBITOR MOVE-IN

For more information and helpful hints on pre-show procedures and move-in, please go to [www.freemanco.com/preshowFAQ](http://www.freemanco.com/preshowFAQ)

Friday            September 25, 2015      10:00 AM - 12:00 PM

### EXHIBIT HOURS

Friday            September 25, 2015      12:00 PM - 4:00 PM

### EXHIBITOR MOVE-OUT

For more information and helpful hints on post-show procedures and move-out, please go to [www.freemanco.com/postshowFAQ](http://www.freemanco.com/postshowFAQ)

Friday            September 25, 2015      4:00 PM - 5:00 PM

### DISMANTLE AND MOVE-OUT INFORMATION

All exhibitor materials must be removed from the exhibit facility by Friday, September 25, 2015 at 5:00 PM.

To ensure all exhibitor materials are removed from the exhibit facility by the Exhibitor Move-Out deadline, please have all carriers check-in by Friday, September 25, 2015 at 4:00 PM.

### POST SHOW PAPERWORK AND LABELS

Our Exhibitor Services Department will gladly prepare your outbound Material Handling Agreement and labels in advance. Complete the Outbound Shipping form and your paperwork will be available at show site. Be sure your carrier knows the company name and booth number when making arrangements for shipping your exhibit at the close of the show.

SERVICE CONTRACTOR CONTACTS / INFORMATION:

FREEMAN

9258 Park South View, Ste 100  
Houston, TX 77051  
(713) 770-6750 fax (469) 621-5613  
FreemanHoustonES@freemanco.com

FREEMAN EXHIBIT TRANSPORTATION

(800) 995-3579 US & Canada or + (512) 982-4187 Outside the US or +(817) 607-5183  
International Shipping Services or fax (469) 621-5810 or email exhibit.transportation@freemanco.com

FREEMAN ONLINE®

**Take advantage of discount pricing by ordering online at [www.freemanco.com/store](http://www.freemanco.com/store) by September 16, 2015.** Our Internet online ordering service, Freeman Online® is available for your convenience to order all Freeman Services, view show schedule, or print order forms. Once your show is available online you will receive an email which includes a direct link to Freeman Online®. To place online orders you will be required to enter your unique Login ID and Password. If this is your first time to use Freeman Online®, click on the "Login" link to create a new account. To access Freeman Online® without using the email link, visit [www.freemanco.com/store](http://www.freemanco.com/store) and click the "Login" link. If you need assistance with Freeman Online® please call our Customer Support Center at (888) 508-5054 Toll Free US & Canada or +1(512) 982-4186 Local & International.

SHIPPING INFORMATION

Warehouse Shipping Address:

Exhibiting Company Name / Booth # \_\_\_\_\_  
**UH CT BAUER COLLEGE OF BUSINESS CAREER FAIR**  
C/O FREEMAN  
9258 PARK SOUTH VIEW, STE 100  
HOUSTON, TX 77051

**Please note: The warehouse will be closed on Monday, September 7, 2015 in observance of Labor Day and will not accept shipments.**

Freeman will accept crated, boxed or skidded materials beginning Friday, August 28, 2015, at the above address. Material arriving after September 21, 2015 will be received at the warehouse with an additional after deadline charge. Warehouse materials are accepted at the warehouse Monday through Friday between the hours of 8:00 AM - 3:30 PM.

Show Site Shipping Address:

Exhibiting Company Name / Booth # \_\_\_\_\_  
**UH CT BAUER COLLEGE OF BUSINESS CAREER FAIR**  
C/O FREEMAN  
HILTON UNIVERSITY OF HOUSTON  
4800 CALHOUN, CONRAD, SHAMROCK, WALDORF BALLROOM  
HOUSTON, TX 77204

Freeman will receive shipments at the exhibit facility beginning Friday, September 25, 2015 at 10:00 AM. Shipments arriving before this date may be refused by the facility. Any charges incurred for early freight accepted by the facility are the responsibility of the Exhibitor.

Please note: All items and materials that must be brought into the facility may be subject to Material Handling Charges and are the responsibility of the Exhibitor. This also applies to items not ordered through the Official Show Vendors. Refer to the Material Handling form for charges for this service.

#### LABOR INFORMATION

Union Labor may be required for your exhibit installation and dismantle. Please carefully read the UNION RULES AND REGULATIONS to determine your needs. Exhibitors supervising Freeman labor will need to pick up and release their labor at the Labor Desk. Refer to the order form for Display Labor for Straight time and Overtime hours.

#### MATERIAL HANDLING OVERTIME CHARGES

\*Freight moved out of the facility after 4:30 PM on Tuesday, September 25, 2015 will be subject to overtime rates.

#### ASSISTANCE

We want you to have a successful show. If we can be of assistance, please call our Exhibitor Services Department at (713) 770-6750.

WE APPRECIATE YOUR BUSINESS!

## FREEMAN GENERAL INFORMATION

### TRANSLATION SERVICES

Freeman is pleased to offer a new service for our international exhibitors that provides quick interpretation and translation in 150 languages. This service will not only interpret for us on a three way conversation, but also translate emails from customers. To access this feature you may contact Freeman Exhibitor Services at (713) 770-6750 or Freeman's Customer Support Center at (888) 508-5054 Toll Free US & Canada or +1(512) 982-4186 Local & International.

### HELPFUL HINTS

#### SAVE MONEY

Order early to take advantage of advance order discount rates, place your order by September 16, 2015.

#### AVOID DELAY

Ship early to avoid delays. Shipments arriving late at show site will cost you money, time and business!

#### SAFETY TIPS

Use a ladder, not a chair. Standing on chairs, tables and other rental furniture is unsafe and can cause injury to you or to others. These objects are not designed to support your standing weight.

Be aware of your surroundings. You are in an active work area with changing conditions during move-in and move-out. Pay attention. Look for obstacles, machinery and equipment that are in use.

Keep your eyes open for scooters and forklifts. The drivers of these vehicles may not be able to see you.

Stay clear of dock areas, trucks and trailers. These areas can be particularly dangerous.

Prevent electrical shocks, falling items and damage to materials. Do not attach items or equipment to the drapes or metal framework provided for your booth. This can cause serious injury or damage to materials.

We discourage children from being in the exhibit hall during installation and dismantle. If children are present during installation and dismantle, they must be supervised by an adult at all times.

Freeman does not ship or handle Hazardous Materials. If any materials you are shipping to the event fall into this category, please contact Freeman to be sure the material will be allowed at the facility and by the association. In addition, if authorized by the facility and the association, you will need to make separate arrangements for the transport and handling of the approved materials, since Freeman will not transport or handle them.

The operation or use of all motorized lifts and motorized material handling equipment for installation/dismantle of exhibits is NOT permitted by exhibitors or by their exhibitor appointed contractors (EAC's). Thank you for your cooperation.

### EXHIBITOR ASSISTANCE

Call Freeman's Exhibitor Services department at (713) 770-6750 with any questions or needs you may have.

For more information and helpful hints on pre-show procedures and move-in, please go to [www.freemanco.com/preshowFAQ](http://www.freemanco.com/preshowFAQ).

For more information and helpful hints on post-show procedures and move-out, please go to [www.freemanco.com/postshowFAQ](http://www.freemanco.com/postshowFAQ).



## Reducing Your Footprint

*Freeman actively engages in green practices within day-to-day operations and is committed to producing events in the most environmentally friendly way possible. Freeman has collaborated with a number of customers to make their events greener and is dedicated to broadening this effort.*

### Green Tips for Exhibitors

Interested in going Green and saving money with your exhibit booth? Follow these tips to assist you in making your sustainable booth strategies at least cost-neutral, and possibly cost-saving!

#### Supplies and Ordering

- Order exhibit supplies early and utilize online ordering systems to eliminate paper waste.
- Consider renting a booth from Freeman or buying materials locally, preventing shipping cost and lowering emissions.
- Rent Freeman Classic Carpet which contains recycled content and is also recyclable.
- Provide giveaways made of recycled, responsibly grown natural fiber, nontoxic and biodegradable materials. Ensure giveaways are useful, not merely promotional in nature. Electronic Giveaways are smart and trendy, like a USB storage drive with your content already loaded.

#### Printing, Recycling and Waste Management

- Encourage less printing and provide more information digitally when it comes to booth literature, fulfilling requests via email and website referrals.
- If you need to print, use a local printer in the city where the show will be held and choose paper that contains at least 50% post-consumer recycled content.
- Ask Freeman about new paper-based signage materials that are comparably priced to plastic. There are good alternatives to foam core and PVC which are not as easily recyclable.
- Participate in the exhibit donation program by providing materials that are eligible for donation to local charities, such as pens, bags and notepads.

#### Shipping and Transportation

- If you must ship materials, planning out your booth in a timely way to meet shipping deadlines can also help maximize consolidation and cost-savings.
- Choose a SmartWay™-certified hauler at no additional cost to ensure your transportation company is practicing sustainable shipping.
- Set a goal to leave no trace behind by shipping out all booth properties and packing materials and donating extra giveaways thereby minimizing any waste for the show.
- If you are attending another trade show that many of your fellow exhibitors are also participating in, ask your General Service Contractor or Show Management to set up a caravan service to save on fuel emissions—and cost of transportation.



#### Personnel and Best Practices

- Take advantage of local or regional representatives to staff your booth, rather than bringing staff from far away offices, reducing travel cost.
- Bring Green as part of your company message providing recycling bins in your booth and information on what you have done to exhibit in a sustainable way.



These steps can help as we all strive to make smarter and more environmentally sound decisions. For more information on the Freeman Sustainability Initiative, contact [goinggreen@freemanco.com](mailto:goinggreen@freemanco.com)

## **FIRE REGULATIONS – CITY OF HOUSTON**

**REF. CODE: 17.26029@**

**FOLLOWING IS THE WHOLE CODE**

**Sec. 17-26.29. Comply with the following requirements to install, operate or maintain any display, concession, exhibit, show or ride in any building or area for purposes of public entertainment, information and/or merchandising purposes:**

- 1. All tents, awnings, curtains, drapes, and decorations, either interior or exterior, must be constructed of flameproof material, or treated with an approved flameproofing solution. (Treatment shall be renewed as often as may be necessary to maintain the flame proofing effect.)**
- 2. All exits, hallways and aisles leading from buildings and/or tents are to be kept clear and unobstructed at all times.**
- 3. No exit door shall be locked, bolted or otherwise fastened or obstructed when the building is occupied.**
- 4. All sawdust and shavings shall be kept damp at all times.**
- 5. Automobiles, trucks, tractors, machinery and other motor vehicles utilizing flammable fuels, which are placed on display inside any building, shall have no more than two (2) gallons of fuel in the tank; and all fuel tanks shall be locked or effectively sealed and battery cables shall be disconnected from the ignition system. Ignition keys for vehicles on display shall be kept by a responsible person at the display location for removal of such vehicles from the building in the event of emergency.**
- 6. The use of liquified petroleum gases in buildings, tents, or areas used for exhibition purposes is strictly prohibited except that use of such gases for demonstration purposes shall be by special permit from the Fire Marshal in accordance with provisions of Article X of this code.**
- 7. “No Smoking by Order of the Fire Marshal” signs shall be posted and maintained in areas designated by the Fire Marshal in accordance with Article XX. Sec. 20-7 of this code.**
- 8. Trash and rubbish, grease, etc., shall be removed from buildings, tents and areas at least once each day.**
- 9. All electrical wiring shall be installed in a manner approved by the City Electrical Inspector.**
- 10. Approved fire extinguishing equipment shall be provided and maintained in all areas as designated by the Fire Marshal.**
- 11. All standpipe and hose cabinets shall be kept clear and unobstructed at all times.**
- 12. The use of welding and cutting equipment for demonstration purposes shall be approved by the Fire Marshal.**

**(over)**

**FIRE REGULATIONS – CITY OF HOUSTON**  
**PAGE 2**

- 13. The demonstration of equipment using liquid fuel in buildings is prohibited, except as prescribed in Article XX of this code.**
- 14. There shall be no obstructions blocking exit doors from the outside of any building, such as autos parked in doorways, or barricades across the sidewalks.**
- 15. Where smoking is permitted, there shall be provided on each table and at other convenient places suitable noncombustible ashtrays or match receptacles. It shall be an offense for any person to smoke or to carry lighted tobacco in areas within buildings where a trade show is being set up or torn down except in specific areas designated by the Fire Marshal or his representative for smoking tobacco.**
- 16. Each exhibitor shall provide an approved metal container with metal cover for daily accumulation of waste material.**
- 17. All griddles and cook stoves shall be installed at a reasonable and safe distance from all combustible materials and be protected by metal and asbestos protectors.**
- 18. The use of all gas fired heating units, either portable or stationary, shall meet the approval of the City Plumbing Inspector and/or the Fire Marshal. The use of the so-called “Salamander” stove is strictly prohibited.**
- 19. All cooking appliances shall be equipped with ventilating hoods and equipment as deemed necessary by the Fire Marshal, but in any instance such equipment shall be installed in accordance with provisions of the city building and fire codes.**
- 20. All flammable liquids used in any exhibit area shall be stored in an approved underground tank and/or special approved storage room, and dispensed from an approved pump into a vehicle tank or underwriter’s laboratories labeled safety can, in compliance with the fire code.**
- 21. No curtains, drapes, or decorations shall be hung in such a manner, as to cover any exit signs.**
- 22. No vehicles shall be parked in fire lanes outside of buildings.**
- 23. No flammable liquids shall be used or admitted inside of buildings except by approval of the Fire Marshal.**
- 24. Artificial lighting such as lanterns and candles are prohibited, except when approved by the Fire Marshal’s office.**
- 25. No smokeless powder allowed unless authorized by Fire Marshal. Refer to Section 11.8 of the Houston Fire Code.**



# FREEMAN

9258 Park South View, Suite 100  
Houston, Texas 77051  
Ph: 713-770-6750 • Fax: 469-621-5613  
FreemanHoustonES@freemanco.com

**DISCOUNT PRICE  
DEADLINE DATE  
SEPTEMBER 16, 2015**

**INCLUDE THIS FORM  
WITH YOUR ORDER  
PLEASE USE BLACK INK**

NAME OF SHOW: **UH CT BAUER COLLEGE OF BUSINESS CAREER FAIR / SEPT 25, 2015**

COMPANY NAME: \_\_\_\_\_ BOOTH#: \_\_\_\_\_

ADDRESS: \_\_\_\_\_ BOOTH SIZE: \_\_\_\_\_ X \_\_\_\_\_

CITY/STATE/ZIP: \_\_\_\_\_ CUSTOMER # \_\_\_\_\_

PHONE #: \_\_\_\_\_ EXT.: \_\_\_\_\_ FAX #: \_\_\_\_\_

SIGNATURE: \_\_\_\_\_ PRINT NAME: \_\_\_\_\_

CONTACT'S E-MAIL \_\_\_\_\_

E-MAIL FOR INVOICE \_\_\_\_\_  CHECK IF YOU ARE A NEW FREEMAN CUSTOMER

**Invoices will be sent by e-mail; please provide the e-mail address of the person who reconciles your invoices if different than contact's email.**

## METHOD OF PAYMENT

BY SUBMITTING THIS FORM VIA FAX OR POSTAL MAIL OR ORDERING MATERIALS OR SERVICES FROM FREEMAN, YOU AGREE TO BE BOUND BY ALL TERMS & CONDITIONS INCLUDED IN YOUR SERVICE MANUAL.

- COMPANY CHECK**  
Please make check payable to: Freeman. Checks must be in U.S. funds drawn on a U.S. or Canadian bank. ("US FUNDS" MUST BE PRE-PRINTED on Canadian checks.)  
**Please reference (423425) on your remittance.**
- BANK TRANSFER**  
Bank Transfer to Bank of America, N.A.; Dallas, TX  
*Wire Transfer*  
ABA#: 026009593 ACCT #1252039192 Freeman  
*International Wire Transfer*  
Swift Code: BOFAUS3N ACCT #1252039192 Freeman  
*ACH Direct Deposit*  
ABA# 121000012 ACCT #1252039192 Freeman  
**Please reference Name of Show & Booth Number so we can properly credit your account.**  
**Note: Customers are responsible for any bank processing fees.**
- CREDIT/CREDIT CARD**  
For your convenience, we will use this authorization to charge your credit/debit card account for your advance orders, and any additional amounts incurred as a result of show site orders placed by your representative. These charges may include all Freeman companies, or any charges which Freeman may be obligated to pay on behalf of Exhibitor, including without limitation, any shipping charges. Please complete the information requested below:
- AMERICAN EXPRESS**     **MASTERCARD**     **VISA**    **FREEMAN NOW ACCEPTS DEBIT CARDS**

Account No.: \_\_\_\_\_ Exp. Date: \_\_\_\_\_

Cardholder Name (Print): \_\_\_\_\_ Signature: \_\_\_\_\_

Cardholder Billing Address: \_\_\_\_\_

City/State/Zip: \_\_\_\_\_

## ENTER TOTALS HERE

FURNISHINGS & ACCESSORIES	CARPET	CLEANING	RENTAL EXHIBITS & ACCESSORIES	INSTALLATION LABOR	DISMANTLE LABOR	MATERIAL HANDLING	
RIGGING INSTALLATION	RIGGING DISMANTLE	HANGING SIGNS	SIGNS	EXHIBIT TRANSPORTATION			GRAND TOTAL

- Remember to order in advance to save time and money. You may place your order by phone, fax, mail, or use our online ordering service at: [www.freemanco.com/store](http://www.freemanco.com/store). **We do not accept credit card information via email.**
- Orders received without payment or after the discount price deadline date will be charged at the standard price.
- Copies of invoices may be picked up from the Service Desk prior to show closing.
- If you have questions or need assistance with any items not listed, please call and ask for your Exhibitor Services Representative.

### TELL US WHAT YOU THINK!

Freeman is committed to providing great customer service. To help us serve you more effectively in the future, please visit the URL address below upon the completion of your show to provide feedback. Your input will provide the insight needed to ensure that our customer service is in line with your expectations.

<http://feedback.freemanco.com/?423425>

FREEMAN method of payment

# FREEMAN

9258 Park South View, Ste 100  
Houston, TX 77051  
(713) 770-6750 Fax: (469) 621-5613

## UH CT BAUER COLLEGE OF BUSINESS CAREER FAIR / SEPT 25, 2015

In order to authorize Freeman to invoice a third party for payment of services rendered to exhibitors, both the exhibiting company and the third party must complete this form and return it at least 14 days prior to show move-in.

### EXHIBITING COMPANY AUTHORIZATION OF THIRD PARTY BILLING

"We understand and agree that we, the exhibiting company, are ultimately responsible for payment of charges and agree by submitting this form or ordering materials or services from Freeman, to be bound by all terms and conditions as described in the Terms & Conditions section of this service manual. In the event that the named third party does not discharge payment of the invoice prior to the last day of the show, charges will revert back to the exhibiting company. All invoices are due and payable upon receipt, by either party. The items checked below are to be invoiced to the third party."

BY SUBMITTING THIS FORM VIA FAX OR POSTAL MAIL OR ORDERING MATERIALS OR SERVICES FROM FREEMAN, YOU AGREE TO BE BOUND BY ALL TERMS & CONDITIONS INCLUDED IN YOUR SERVICE MANUAL.

EXHIBITOR NAME: (PLEASE PRINT)

EXHIBITOR SIGNATURE:

DATE:

### EXHIBITING COMPANY INFORMATION

EXHIBITING COMPANY NAME:

BOOTH #:

EXHIBITING COMPANY ADDRESS:

CITY/STATE/ZIP:

PHONE:

EXT:

FAX:

CONTACT'S E-MAIL:

### Indicate which services are to be invoiced to the Third Party:

- |   |   |
|---|---|
| <input type="checkbox"/> ALL FREEMAN SERVICES       | <input type="checkbox"/> FREEMAN EXHIBIT TRANSPORTATION |
| <input type="checkbox"/> I&D LABOR/SUPERVISION      | <input type="checkbox"/> RENTAL FURNITURE/CARPET/SIGNS  |
| <input type="checkbox"/> MATERIAL HANDLING/IN & OUT | <input type="checkbox"/> BOOTH CLEANING                 |
|   | <input type="checkbox"/> OTHER _____                    |

### THIRD PARTY COMPANY INFORMATION

THIRD PARTY COMPANY NAME:

CONTACT NAME:

THIRD PARTY BILLING ADDRESS:

CITY/STATE/ZIP:

PHONE:

EXT:

FAX:

CONTACT'S E-MAIL:

E-MAIL FOR INVOICE:

Invoices will be sent by e-mail; please provide the e-mail address of the person who reconciles your invoices if different than contact's e-mail.

### THIRD PARTY CREDIT/DEBIT CARD AUTHORIZATION

AMERICAN EXPRESS  MASTERCARD  VISA **FREEMAN NOW ACCEPTS DEBIT CARDS**

ACCOUNT NO:

EXP. DATE:

CARDHOLDER NAME (PLEASE PRINT):

CARD TYPE:

AUTHORIZED SIGNATURE:

CARDHOLDER BILLING ADDRESS:

CITY/STATE/ZIP:

07/15 (423425)

FREEMAN third party authorization

# PAYMENT & LABOR

YOU ARE ENTERING A CONTRACT WHICH LIMITS YOUR POSSIBLE RECOVERY IN CASE OF LOSS OR DAMAGE. The terms and conditions set forth below become a part of the Contract between Freeman and you, the Exhibitor. Acceptance of said terms and conditions will be construed when any of the following conditions are met:

- THE METHOD OF PAYMENT FORM IS SIGNED; OR
- AN ORDER FOR LABOR, SERVICES AND/OR RENTAL EQUIPMENT IS PLACED BY EXHIBITOR WITH FREEMAN; OR
- WORK IS PERFORMED ON BEHALF OF EXHIBITOR BY FREEMAN.

## DEFINITIONS

For purposes of this Contract, Freeman means Freeman Expositions, Inc. and its respective employees, directors, officers, agents, assigns, affiliated companies, and related entities including, but not limited, to any subcontractors Freeman may appoint. The term "Exhibitor" means the Exhibitor, its employees, agents, or representatives.

## PAYMENT TERMS

Full payment, including any applicable tax, is due in advance or at show site. All payments must be in U.S. funds and all checks must be drawn on a U.S. bank. Orders received without advance payment or after the deadline date will incur additional After Deadline charges as indicated on each order form. All materials and equipment are on a rental basis for the duration of the show or event and remain the property of Freeman except where specifically identified as a sale. All rentals include delivery, installation, and removal from Exhibitor's booth. In case of cancellation of any orders or services by Exhibitor, a one-hour "per person, per hour" charge will be applied for all labor orders that are not canceled in writing at least 24 hours prior to the scheduled start time. If Prestige Carpet, Custom-Cut Carpet, Modular Rental Exhibits and any other custom-order items or services have already been provided at the time of cancellation, fees will remain at 100% of the original charge. If the Show or Event is canceled because of reasons beyond Freeman's control, Exhibitor remains responsible for all charges for services and equipment provided up to and including the date of cancellation. Freeman will not issue refunds to Exhibitor of any payments made before the date of cancellation. It is Exhibitor's responsibility to advise the Freeman Service Center Representative of problems with any orders, and to check the Exhibitor's invoice for accuracy prior to the close of the Show or Event. If Exhibitor is exempt from payment of sales tax, Freeman requires an exemption certificate for the State in which the services are to be used. Resale certificates are not valid unless Exhibitor is rebilling these charges to its customers. For International Exhibitors, Freeman requires 100% prepayment of advance orders, and any order or services placed at show site must be paid at the show. For all others, should there be any pre-approved unpaid balance after the close of the show; terms will be net, due and payable in DALLAS, TEXAS upon receipt of invoice. Effective 30 days after invoice date, any unpaid balance will bear a FINANCE CHARGE at the lesser of the maximum rate allowed by applicable law, or 1.5% per month, which is an ANNUAL PERCENTAGE RATE of 18%, and future orders will be on a prepaid basis only. If any finance charge hereunder exceeds the maximum rate allowed by applicable law, the finance charge shall automatically be reduced to the maximum rate allowed, and any excess finance charge received by Freeman shall be either applied to reduce the principal unpaid balance or refunded to the payer. If past due invoices or invoice balances are placed with a collection agency or attorney for collection or suit, Exhibitor agrees to pay all legal and collection costs. THESE PAYMENT TERMS AND CONDITIONS SHALL BE GOVERNED BY AND CONSTRUED IN ACCORDANCE WITH THE LAWS OF THE STATE OF TEXAS. In the event of any dispute between the Exhibitor and Freeman relative to any loss, damage, or claim, such Exhibitor shall not be entitled to and shall not withhold payment, or any partial payment, due to Freeman for its services, as an offset against the amount of any alleged loss or damage. Any claims against Freeman shall be considered a separate transaction, and shall be resolved on its own merits. Freeman reserves the right to charge Exhibitor for the difference between the Exhibitor's estimate of charges and the actual charges incurred by Exhibitor, or for any charges that Freeman may be obligated to pay on behalf of Exhibitor, including without limitation, any shipping charges. If Exhibitor provides a credit card for payment and charges are rejected by the Exhibitor's credit card company for any reason, Freeman hereby provides notice that it reserves the right, and Exhibitor authorizes Freeman, to continue to attempt to secure payment through that credit card for as long as unpaid balances remain on the Exhibitor's account.

## ELECTRICAL

Claims will not be considered, or adjustments made unless filed in writing, by Exhibitor, prior to the close of the event. Freeman is not responsible for any damage or loss caused by the loss of power beyond its control and Exhibitor agrees to hold Freeman, its officers, directors, employees and agents harmless from such power loss. IN NO EVENT SHALL FREEMAN BE LIABLE FOR ANY INDIRECT OR CONSEQUENTIAL DAMAGES (INCLUDING WITHOUT LIMITATION LOST PROFITS) EVEN IF ADVISED OF THE POSSIBILITY OF SUCH DAMAGES, WHETHER UNDER THEORY OF CONTRACT, TORT (INCLUDING NEGLIGENCE), PRODUCTS LIABILITY OR OTHERWISE. Exhibitor shall indemnify and hold harmless Freeman, its officers, directors, employees, and agents from and against any and all claims, liabilities, damages, fines, penalties or costs of whatsoever nature (including reasonable attorneys' fees) arising out of or in any way connected with Exhibitor's actions or omissions under this Agreement.

## LABOR UNDER THE SUPERVISION OF EXHIBITOR RESPONSIBILITIES:

Exhibitor shall be responsible for the performance of labor provided under this option. It is the responsibility of Exhibitor to supervise labor secured through Freeman in a reasonable manner as to prevent bodily injury and/or property damage and also to direct them to work in a manner that is in compliance with Freeman's Safe Work Rules and/or Federal, State, County and Local ordinances, rules and/or regulations, including but not limited to Show or Facility Management rules and/or regulations. It is the responsibility of Exhibitor to check in with the Service Desk to pick up labor, and to return to the Service Desk to release labor when the work is completed.

## INDEMNIFICATION:

Exhibitor agrees to indemnify, hold harmless, and defend Freeman from and against any and all demands, claims, causes of action, fines, penalties, damages, liabilities, judgments, and expenses (including but not limited to reasonable attorneys' fees and investigation costs) arising out of or occasioned by the acts or omissions of Exhibitor. The Exhibitor's indemnification of Freeman includes any and all violations of Federal, State, County or Local ordinances, Show or Event Regulations and/or Rules as published and/or set forth by Facility or Show Management, and/or directing labor provided by Freeman to work in a manner that violates any of the above rules, regulations, and/or ordinances.

## IMPORTANT

PLEASE REFER TO FREEMAN'S "MATERIAL HANDLING TERMS & CONDITIONS" AS IT RELATES TO MATERIAL HANDLING SERVICES AND TO THE "SERVICE REQUEST & SHIPPING INSTRUCTIONS CONTRACT" AS IT RELATES TO TRANSPORTATION SERVICES. CONTRACT TERMS DEPEND ON THE NATURE OF SERVICES SECURED BY EXHIBITOR THROUGH FREEMAN. TERMS & CONDITIONS MAY VARY FOR EACH TYPE OF SERVICE ORDERED THROUGH FREEMAN.

# MATERIAL HANDLING

**YOU ARE ENTERING A BINDING CONTRACT WHICH LIMITS YOUR POSSIBLE RECOVERY IN CASE OF LOSS OR DAMAGE.** Acceptance of said terms and conditions will be construed when any of the following conditions are met: This Material Handling Agreement (MHA) is signed; Exhibitor's materials are delivered to Freeman's warehouse or to an event site for which Freeman is the Official Show Contractor; or an order for labor and/or rental equipment is placed by Exhibitor with Freeman.

**1. DEFINITIONS.** For purposes of this Contract, Freeman means Freeman Expositions, Inc., and its employees, directors, officers, agents, assigns, affiliated companies, and related entities. In no event shall Freeman be deemed to be the Ultimate Consignee for shipping and custom purposes. The term "Exhibitor" means the Exhibitor, its employees, agents, and representatives.

**2. PACKAGING/CRATES AND STORAGE.** Freeman shall not be responsible for damage to loose or uncrated materials, pad wrapped or shrink-wrapped materials, glass breakage, concealed damage, carpets in bags or poly, or improperly packed or labeled materials. Freeman shall not be responsible for crates and packaging which are unsuitable for handling, in poor condition, or have prior damage. Crates and packaging should be of a design to adequately protect contents for handling by forklift and similar means. Freeman does not accept any crates or packaging containing hazardous materials. Goods requiring cold storage and those in accessible storage are stored at Exhibitor's own risk. **FREEMAN ASSUMES NO RESPONSIBILITY OR LIABILITY FOR LOSS OR DAMAGE TO GOODS IN COLD STORAGE OR ACCESSIBLE STORAGE.**

**3. EMPTY CONTAINERS.** Empty container labels will be available at the show site service desk. Affixing labels to the containers is the sole responsibility of Exhibitor or its representative. All previous labels must be removed or obliterated. Freeman assumes no responsibility for: error in the above procedures; removal of containers with old empty labels and without Freeman labels; or improper information on empty labels. **FREEMAN WILL NOT BE LIABLE FOR LOSS OR DAMAGE TO CRATES AND CONTAINERS OR THEIR CONTENTS WHILE SAME ARE IN EMPTY CONTAINER STORAGE.**

**4. INBOUND/OUTBOUND SHIPMENTS.** There may be a lapse of time between the delivery of shipment(s) to the booth and the arrival of Exhibitor, or a lapse of time between the completion of packing and the actual pickup of materials from the booths for loading onto a carrier and during such times, Exhibitor materials will be left unattended. **FREEMAN IS NOT RESPONSIBLE OR LIABLE FOR ANY LOSS, DAMAGE, THEFT, OR DISAPPEARANCE OF EXHIBITOR'S MATERIALS AFTER THEY HAVE BEEN DELIVERED TO EXHIBITOR'S BOOTH AT SHOW SITE OR BEFORE THEY HAVE BEEN PICKED UP FOR RELOADING AT THE CONCLUSION OF THE EVENT.** Freeman recommends the securing of security services from Facility or Show Management. All MHA's submitted to Freeman by Exhibitor will be checked at the time of pickup from the booth and corrections will be made where discrepancies exist between the quantities of items on any form submitted to Freeman and the actual count of such items in the booth at the time of pickup. Freeman is not responsible for any wait time or other charges including business center charges arising from delivery or pickup of Exhibitor's materials.

**5. DELIVERY TO THE CARRIER FOR RELOADING.** Freeman assumes no responsibility for loss, damage, theft, or disappearance of Exhibitor's materials after same have been delivered to Exhibitor's appointed carrier, shipper, or agent for transportation after the conclusion of the show. Freeman loads the materials onto the carrier under directions from the carrier or driver of that carrier. Any loading onto the carrier will be understood to be under the exclusive supervision and control of the carrier or driver of that carrier. **FREEMAN ASSUMES NO RESPONSIBILITY FOR LOSS, DAMAGE, THEFT OR DISAPPEARANCE OF EXHIBITOR'S MATERIALS THAT ARISES OUT OF IMPROPERLY LOADED OR LABELED MATERIALS.**

**6. DESIGNATED CARRIERS.** Freeman shall have the authority to change the Exhibitor designated carrier if that carrier does not pick up the shipment(s) at the appointed time. Where no disposition is made by Exhibitor, materials may be taken to a warehouse to await Exhibitor's shipping instructions and Exhibitor agrees to be responsible for charges relating to such rerouting and handling. **IN NO EVENT SHALL FREEMAN BE RESPONSIBLE FOR ANY LOSS RESULTING FROM SUCH REROUTING DESIGNATION.**

**7. FORCE MAJEURE.** Freeman's performance hereunder is subject to, and Freeman shall not be responsible for loss, delay, or damage due to, strike, work stoppages, natural elements, vandalism, Act of God, civil disturbances, power failures, explosions, acts of terrorism or war, or for any other cause beyond Freeman's reasonable control, nor for ordinary wear and tear in the handling of Exhibitor's materials.

**8. CLAIM(S) FOR LOSS.** Exhibitor agrees that any and all claims for loss or damage must be submitted to Freeman immediately at the show site and in any case not later than **thirty (30) business days** after the date when Exhibitor's materials are delivered to the carrier for transportation from show site or from Freeman's warehouse. All claims reported after thirty (30) days will be rejected. In no event shall a suit or action be brought against Freeman **more than one (1) year** after the date of loss or damage occurred.

**a. PAYMENT FOR SERVICES MAY NOT BE WITHHELD.** In the event of any dispute between the Exhibitor and Freeman relative to any loss, damage, or claim, Exhibitor shall not be entitled to and shall not withhold payment due Freeman for its services as an offset against the amount of any alleged loss or damage. Any claims against Freeman shall be considered a separate transaction and shall be resolved on their own merits.

**b. MAXIMUM RECOVERY.** If found liable for any loss, Freeman's sole and exclusive maximum liability for loss or damage to Exhibitor's materials and Exhibitor's sole and exclusive remedy is limited to \$.50 (USD) per pound per article with a maximum liability of \$100.00 (USD) per item, or \$1,500.00 (USD) per shipment whichever is a less. For unmarked, unlabeled and improperly packaged television monitors, the maximum liability is the lesser of \$3.00 (USD) per pound or the actual invoice price. All shipment weights are subject to correction and final charges determined by the actual or re-weighed weight of the shipment.

**c. LIMITATION OF LIABILITY.** IN NO EVENT SHALL FREEMAN BE LIABLE TO THE EXHIBITOR OR TO ANY OTHER PARTY FOR SPECIAL, COLLATERAL, EXEMPLARY, INDIRECT, INCIDENTAL, OR CONSEQUENTIAL DAMAGES, WHETHER SUCH DAMAGES OCCUR EITHER PRIOR OR SUBSEQUENT TO, OR ARE ALLEGED AS A RESULT OF, TORTIOUS CONDUCT, FAILURE OF THE EQUIPMENT OR SERVICES OF FREEMAN OR BREACH OF ANY OF THE PROVISIONS OF THIS CONTRACT, REGARDLESS OF THE FORM OF ACTION, WHETHER IN CONTRACT OR IN TORT, INCLUDING STRICT LIABILITY AND NEGLIGENCE, EVEN IF FREEMAN HAS BEEN ADVISED OR HAS NOTICE OF THE POSSIBILITY OF SUCH DAMAGES. SUCH EXCLUDED DAMAGES INCLUDE BUT ARE NOT LIMITED TO LOST PROFITS, LOSS OF USE, AND INTERRUPTION OF BUSINESS OR OTHER CONSEQUENTIAL OR INDIRECT ECONOMIC LOSSES.

**9. DECLARED VALUE.** Declarations of Declared Value are between the Exhibitor and the selected Carrier ONLY, and are in no way an extension of Freeman's maximum liability stated herein. Freeman will use commercially reasonable efforts to transmit the Declared Value instructions to the selected Carrier; however, **FREEMAN WILL NOT BE LIABLE FOR ANY CLAIM ARISING FROM THE TRANSMITTAL OF, OR FAILURE TO TRANSMIT, DECLARED VALUE INSTRUCTIONS TO THE CARRIER NOR FOR FAILURE OF THE CARRIER TO UPHOLD THE DECLARED VALUE OR ANY OTHER TERM OF CARRIAGE.**

**10. JURISDICTION / VENUE.** THIS CONTRACT SHALL BE CONSTRUED UNDER THE LAWS OF THE STATE OF TEXAS WITHOUT GIVING EFFECT TO ITS CONFLICT OF LAWS RULES. EXCLUSIVE VENUE FOR ALL DISPUTES ARISING OUT OF OR RELATING TO THIS CONTRACT SHALL RESIDE IN A COURT OF COMPETENT JURISDICTION IN DALLAS COUNTY, TEXAS.

**11. INDEMNIFICATION.** Exhibitor agrees to indemnify and forever hold harmless Freeman from and against any and all demands, claims, causes of action, fines, penalties, damages (including consequential), liabilities, judgments, and expenses (including but not limited to reasonable attorneys' fees and investigation costs) arising out or contributed to by Exhibitor's negligent supervision of any labor secured through Freeman; Exhibitor's negligence, willful misconduct, or deliberate act, or the negligence, willful misconduct, or deliberate act of Exhibitor's employees, agents, representatives, customers, invitees and/or any Exhibitor Appointed Contractors (EAC) at the show or event to which this Contract relates, including but not limited to Exhibitor's violation of Federal, State, County or Local ordinance and/or Exhibitor's violation of Show Regulations and/or Rules as published and set forth by Facility and/or Show Management.

**12. LIEN.** Exhibitor grants Freeman a security interest in and a lien on all of Exhibitor's materials that is from time to time in the possession of Freeman and all the proceeds thereof, including without limitation insurance proceeds (the "Collateral"), to secure the prompt and full payment and performance of all Exhibitor's indebtedness for monies paid, by Freeman on its behalf, services performed, materials and/or labor from time to time provided by Freeman to or for the benefit of Exhibitor ("Obligations"). Freeman shall have all the rights and remedies of a secured party under the Uniform Commercial Code, as may be amended from time to time ("UCC"), and any notice that Freeman is required to give under the UCC of a time and place of a public sale or the time after which any private sale or other intended disposition of any Collateral is to be made shall be deemed to constitute reasonable notice if such notice is mailed by registered or certified mail at least five (5) days prior to such action. Freeman may hold and not deliver any of the Collateral to Exhibitor for so long as there are any Obligations that remain unpaid or unsatisfied.

**13. WAIVER & RELEASE.** Exhibitor, as a material part of the consideration to Freeman for material handling services, waives and releases all claims against Freeman with respect to all matters for which Freeman has disclaimed liability pursuant to the provisions of this Contract.

**14. DRIVER LIABILITY WAIVER.** IN CONSIDERATION OF FREEMAN PERMITTING ENTRANCE TO THE PREMISES, YOU, YOUR EMPLOYER, THE OWNER OF THE TRUCK AND/OR EQUIPMENT THAT YOU ARE OPERATING (TRUCKOWNER) AND YOU AS AGENT OF YOUR EMPLOYER AND THE TRUCKOWNER, HEREBY ASSUME ALL RISK OF INJURY OR HARM TO YOURSELF AND OTHERS AND DAMAGE TO YOUR PROPERTY AND PROPERTY BELONGING TO YOUR EMPLOYER OR OTHERS ARISING FROM YOUR ACTIVITIES WHILE BEING PERMITTED TO ENTER THE PREMISES. YOU AGREE TO ENTER AT YOUR OWN RISK. YOU HAVE FULL KNOWLEDGE OF ANY RISK INVOLVED IN THIS ACTIVITY. YOU RECOGNIZE THE HAZARDS AND ARE AWARE OF ALL THE RULES FOR SAFE OPERATION. YOUR EMPLOYER, THE TRUCKOWNER, AND YOU AGREE TO INDEMNIFY AND HOLD HARMLESS FREEMAN, ITS EMPLOYEES, OFFICERS, DIRECTORS, AGENTS, ASSIGNS, AFFILIATED COMPANIES AND RELATED ENTITIES, AGAINST ANY AND ALL LIABILITY, ACTIONS, CLAIMS, AND DAMAGES OF ANY KIND WHATSOEVER ARISING FROM YOUR ACTIVITIES WHILE BEING PERMITTED TO ENTER THE PREMISE.

# EXHIBIT transportation



There are many transportation carriers to choose from, but Freeman has more than 85 years of experience in the events industry. No one understands exhibit transportation better than Freeman. Allow us to make the shipping process easy for you.

Between our cost effective solutions, superior customer service and all inclusive pricing, you will find Freeman Exhibit Transportation to be reputable, reliable and convenient. Our transportation experts have the ability to quickly respond to changes when necessary and are available to assist you with all of your show requirements.

*Don't forget about inbound shipping! Complete and send the order form to order your inbound and outbound shipping.*

# EXHIBIT TRANSPORTATION **services**

As the official service contractor, Freeman partners with you and with decision makers at show site – making it easier for you to transport your exhibit to any location.

Some of the benefits of working with Freeman Exhibit Transportation include:

- Guaranteed all inclusive pricing with no additional fees for pickups and deliveries, including weekend and night service.
- One convenient invoice with all your Freeman show services.
- On site transportation experts are available before, during and after the show.
- Customer service seven days a week, offering complete shipment visibility and expert oversight.

## **questions?**

For more information regarding our services, rates, shipment deadlines, documentation requirements, ordering and the terms and conditions of our service offerings, please visit [www.freemanco.com](http://www.freemanco.com)

Continental U.S. Exhibitors: Contact our exhibit transportation experts at 800.995.3579 or via email at [exhibit.transportation@freemanco.com](mailto:exhibit.transportation@freemanco.com)

International Exhibitors: Contact our exhibit transportation experts at +1.817.607.5183 or via email at [international.freight@freemanco.com](mailto:international.freight@freemanco.com)

**F R E E M A N**



# FREEMAN

(800) 995-3579 Toll Free US & Canada  
(817) 607-5100 Local & International

COMPLETE THIS FORM ONLY IF YOU ARE SHIPPING YOUR EXHIBIT MATERIALS BY FREEMAN EXHIBIT TRANSPORTATION

NAME OF SHOW: **UH CT BAUER COLLEGE OF BUSINESS CAREER FAIR / SEPT 25, 2015**

COMPANY NAME: \_\_\_\_\_ BOOTH #: \_\_\_\_\_ BOOTH SIZE: \_\_\_\_\_ X

CONTACT NAME : \_\_\_\_\_ PHONE #: \_\_\_\_\_

E-MAIL ADDRESS : \_\_\_\_\_

For Assistance, please call applicable number listed above to speak with one of our experts.

For fast, easy ordering, go to [www.freemanco.com/store](http://www.freemanco.com/store)

## EXHIBIT TRANSPORTATION

### TIPS FOR EASY ORDERING

- Credit card information must be on file prior to pick up, as charges will be included on your show services invoice.
- International Exhibitors remember - Shipments originating from countries other than the U.S. must be cleared through customs. Please call for additional information:  
(800) 995-3579 Toll Free US & Canada  
(817) 607-5100 Local & International

### COMPLETE THE FOLLOWING ITEMS ON THIS FORM:

#### PICK UP INFORMATION

Requested Pick Up Date: \_\_\_\_\_

SHIPPER NAME \_\_\_\_\_

SHIPPER ADDRESS \_\_\_\_\_

\_\_\_\_\_

(City) (State) (Zip)

#### DESTINATION

- I will be shipping to the **WAREHOUSE**

**FREEMAN / Exhibiting Company Name / Booth #**  
**UH CT BAUER COLLEGE OF BUSINESS CAREER FAIR**  
 C/O: FREEMAN  
 9258 PARK SOUTH VIEW, STE 100  
 HOUSTON, TX 77051  
**MUST BE DELIVERED BY SEPTEMBER 21, 2015**

- I will be shipping to **SHOW SITE**

**FREEMAN / Exhibiting Company Name / Booth #**  
**UH CT BAUER COLLEGE OF BUSINESS CAREER FAIR**  
 C/O: FREEMAN  
 HILTON UNIV OF HOUSTON  
 4800 CALHOUN, CONRAD, SHAMROCK, WALDORF  
 BALLROOMS  
 HOUSTON, TX 77204  
**CANNOT BE DELIVERED BEFORE SEPTEMBER 25, 2015**

#### TYPE OF SERVICE

- Next Day Air: Delivery next business day by 5:00 PM  
 Second Day Air: Delivery second business day by 5:00 PM  
 3-5 Day Service: Delivery within 3 - 5 business days  
 Declared Value \$ \_\_\_\_\_

**Air Transportation charges are billed by Dimensional or Actual Weight, whichever is greater.**

- Standard Ground: Dependent on distance  
 Expedited Ground: Tailored to specific requirements  
 Specialized: Pad wrapped, uncrated, truck load

### SHIPPING INFORMATION

#### Items to be shipped

Number of Pieces	Est. Weight
____ Crates (wooden)	_____
____ Cartons (cardboard)	_____
____ Cases/Trunks (fiber) (color _____)	_____
____ Skids/Pallets	_____
____ Carpet (color _____)	_____
____ Other ( _____ )	_____
____ Total	_____

Size of largest piece: (H) \_\_\_\_\_ (W) \_\_\_\_\_ (L) \_\_\_\_\_

**NOTE: Shipments will be weighed and measured prior to delivery.**

#### OUTBOUND SHIPPING

- I would like to schedule outbound Freeman Exhibit Transportation. Please provide me with a Material Handling Agreement at show site for my shipping instructions and signature. So we may print your Outbound Material Handling Agreement and labels, please complete the following information **if different from pick up address:**

Ship to address:  
 \_\_\_\_\_  
 \_\_\_\_\_  
 \_\_\_\_\_  
 \_\_\_\_\_

Number of Labels : \_\_\_\_\_

#### FAX THIS COMPLETED FORM VIA:

**E-mail:**

**[exhibit.transportation@freemanco.com](mailto:exhibit.transportation@freemanco.com)**

**or**

**Fax: (469) 621-5810**

**A TRANSPORTATION SPECIALIST WILL CALL YOU TO CONFIRM RECEIPT OF ORDER AND FINALIZE DETAILS.**

**SHOW #** (423425) \_\_\_\_\_

FREEMAN exhibit transportation

# AIR CARGO

## AIR CARGO SERVICE REQUEST AND SHIPPING INSTRUCTIONS CONTRACT

In tendering this shipment, the Shipper and Consignee agree to these TERMS which no agent or employee of the parties may alter. This Air Service Request and Shipping Instruction Contract is NON-NEGOTIABLE and has been prepared by Shipper, or if by Freeman or another on Shipper's behalf, it shall be deemed, conclusively, to have been prepared by the Shipper. The Shipper agrees that this shipment is subject to the TERMS stated herein All TERMS, including but not limited to, all the limitations of liability, shall apply to our agents and their contracting carriers.

**1. DEFINITIONS:** In this Contract, "Freeman" means Freeman Decorating Services, Inc., and its respective employees, officers, directors, agents, assigns, affiliated companies, and related entities including any contractors appointed by Freeman. The term "Shipper" means the person or business for whom the property is being transported, and includes their respective employees, officers, directors, agents, assigns, affiliated companies, and contractors appointed by the Shipper, excluding only Freeman. "Property" is all objects of any type received from the Shipper for transport by Freeman as described herein. "Consignee" is the party to whom Shipper has designated the goods are to be delivered.

**2. FINAL CONTRACT BETWEEN THE PARTIES:** In exchange for Shipper's payments and Freeman's services, which the parties have specified in this two-page Contract (including the Air Cargo Service Request and Shipping Instructions), Freeman and Shipper each agree that this Contract shall govern their respective rights and obligations regarding transportation of Shipper's property. This Contract shall take effect when the property first comes into the physical possession of Freeman, and the responsibility of Freeman under same shall end when the property has been placed in the possession of the Consignee or the Consignee's designated agent. If any part or provision of this Contract is found by a court of competent jurisdiction to be void or unenforceable, the remainder of the Contract shall continue in full force and effect.

**3. Freeman's RESPONSIBILITIES UNDER THE CONTRACT ARE LIMITED:** Freeman is responsible for the satisfactory performance of only those services which it directly provides under this Contract. Freeman shall not be responsible for the performance of individuals of firms who are not under the direct supervision or control of Freeman. Freeman shall not be responsible for events or causes of loss, delay, or damage beyond its reasonable control, including (by way of illustration only, and not as a limitation on the breadth of this clause), strike, lockout, work slowdown or stoppage, power failure, breakdown of plant or machinery, facility failure, vandalism, theft, Act of God, effect of natural elements, riot, civil commotion or disturbance, terrorism, act of war or belligerent parties, and any other cause or causes beyond the reasonable control of Freeman. EXCEPT FOR ELIGIBLE GUARANTEED SERVICE SHIPMENTS, Freeman DOES NOT GUARANTEE DELIVERY BY ANY SPECIFIC TIME OR DATE.

**4. PACKAGING AND CRATES:** Shipper's property must be well packaged for safe and secure handling, storage and shipment using ordinary care. Each piece must be legibly and durably marked with the name and address, including correct ZIP code of the Shipper and Consignee. When a container is used repetitively by Shipper, Shipper must remove all old labels, tags, markings, etc., and Shipper must ensure that the container retains adequate strength for transportation. Freeman makes neither representation nor any warranty regarding the acceptability or suitability of any packaging system or procedure that Shipper might use for its property. Freeman shall not be responsible for damage to loose or uncrated materials, padwrapped or shrink-wrapped materials, glass breakage, concealed damage, carpets in bags or poly, or improperly packed or labeled materials. Crates and packaging should be of a design to adequately protect contents for handling by forklift and similar means. General guidance as to acceptable packaging systems and procedures may be found in publications such as the National Motor Freight Classification, published by the National Motor Freight Traffic Association. For shipments of Perishable Commodities, U.S. and Canadian shipments must be packed to travel without spoilage for 72 hours from time of pickup; all international shipments must be packed to travel without spoilage for 24 hours beyond an agreed deadline. Freeman reserves the right to periodically embargo regions of the world due to conditions that may cause damage to perishable commodities.

**5. REFUSED SHIPMENTS:** If the Consignee refuses a shipment tendered for delivery or if Freeman is unable to deliver a shipment because of fault or mistake of the Consignor or Consignee, Freeman's liability shall then become that of a warehouseman.

(a) Freeman shall promptly attempt to provide notice, by telephonic, electronic or written communication as provided on the face of these shipping instructions, if so indicated, to Shipper or the party, if any, designated to receive notice in these instructions.

(b) Storage charges, based on Freeman's applicable rates, shall start no sooner than the next business day following the attempted notification. Storage may be, at Freeman's option, in any location that provides reasonable protection against loss or damage. Freeman may place the shipment in public storage at the owner's expense and without liability to Freeman.

(c) If Freeman does not receive disposition instructions within 48 hours of the time of Freeman's attempted first notification, Freeman will attempt to issue a second and final confirmed notification. Such notice shall advise that if Freeman does not receive disposition instructions within 10 days of that notification, Freeman may offer the shipment for sale at a public auction and Freeman has the right to offer the shipment for sale. The amount of sale will be applied to Freeman's invoice for transportation, storage and other lawful charges. Shipper will be responsible for the balance of charges not covered by the sale of the goods. If there is a balance remaining after all charges and expenses are paid, such balance will be paid to the owner of the property sold hereunder, upon claim and proof of ownership.

(d) Where Freeman has attempted to follow the procedure set forth above and the procedure is not possible, nothing shall be construed to abridge the right of Freeman, at its option, to sell the property under such circumstances and in such manner as may be authorized by law.

(e) When perishable goods cannot be delivered and disposition is not given within a reasonable time, Freeman may dispose of property to the best advantage. Where Freeman is directed by Consignee or Consignor to unload or deliver property at a particular location where Consignor, Consignee, or the Agent of either is not regularly located, Freeman's liability for the shipment shall terminate after unloading or delivery.

**6. LIMITATION ON SHIPPER'S RECOVERABLE DAMAGES:** FREEMAN'S LIABILITY FOR DAMAGES ON DOMESTIC SHIPMENTS, INCLUDING BUT NOT LIMITED TO THOSE DAMAGES ARISING FROM OR RELATED TO MISDELIVERY, INCOMPLETE OR OTHERWISE INADEQUATE DELIVERY (INCLUDING BUT NOT LIMITED TO FAILURE TO FOLLOW SHIPPER OR CONSIGNEE INSTRUCTIONS OR FAILURE TO COLLECT OR PROPERLY DELIVER A PAYMENT INSTRUMENT), NONDELIVERY, MISSED PICKUP, AND LOSS OF OR DAMAGE TO CARGO, SHALL BE LIMITED TO THE HIGHER OF \$50.00 (USD) PER SHIPMENT OR \$50 (USD) PER POUND (\$1.10 (USD) PER KILOGRAM) OF CARGO ADVERSELY AFFECTED THEREBY, PLUS TRANSPORTATION CHARGES APPLICABLE TO THAT PART OF THE SHIPMENT ADVERSELY AFFECTED THEREBY, UNLESS AT TIME OF SHIPMENT THE SHIPPER MAKES A DECLARATION OF VALUE FOR CARRIAGE IN THE SPACE DESIGNATED ON THE SERVICE REQUEST AND SHIPPING INSTRUCTIONS FORM AND PAYS THE APPROPRIATE VALUATION CHARGE. IN NO EVENT SHALL FREEMAN'S LIABILITY EXCEED THE DECLARED VALUE OF THE SHIPMENT OR THE AMOUNT OF LOSS OR DAMAGE ACTUALLY SUSTAINED, WHICHEVER IS LOWER. IF CARRIAGE OF THE SHIPMENT IS SOLELY OR PARTLY BY AIR AND INVOLVES AN ULTIMATE DESTINATION OR A STOP IN A COUNTRY OTHER THAN THE COUNTRY OF DEPARTURE, Freeman's LIABILITY FOR CARGO LOST, DAMAGED OR DELAYED SHALL BE LIMITED TO \$9.07 PER POUND (\$20.00 PER KILOGRAM) FOR CARRIAGE SUBJECT TO THE UNAMENDED WARSAW CONVENTION OR THE WARSAW CONVENTION AS AMENDED BY THE HAGUE PROTOCOL OF 1955, 17 SPECIAL DRAWING RIGHTS PER KILOGRAM FOR CARRIAGE SUBJECT TO THE WARSAW CONVENTION AS AMENDED BY THE MONTREAL PROTOCOL NO. 4 OF 1975, OR \$9.07 PER POUND (\$20.00 PER KILOGRAM) FOR CARRIAGE WHERE THE WARSAW CONVENTION, INCLUDING ITS AMENDMENTS, DOES NOT APPLY FOR ANY REASON, UNLESS A HIGHER DECLARED VALUE IS REQUESTED, AND THE FEES SET FORTH IN THE SERVICE GUIDE FOR SUCH HIGHER DECLARED VALUE ARE PAID. FOR INTERNATIONAL SHIPMENTS, THIS SHIPPING REQUEST AND SHIPPING INSTRUCTION CONTRACT SHALL BE DEEMED AN AIR WAYBILL WITHIN THE MEANING OF THE WARSAW CONVENTION.

- (a) artworks and objects of art, including without limitation original paintings, drawings, etchings, water colors, tapestries and sculpture;
- (b) clocks, watches, jewelry (including costume jewelry), furs and fur-trimmed clothing;
- (c) personal effects;
- (d) and other inherently fragile or unique items, including prototypes, etc.

Any declared value in excess of the maximums allowed herein is null and void, and the acceptance by Freeman for carriage of any shipment with a declared value in excess of the allowed maximums does not constitute a waiver of these maximums. Shipper understands that even if Shipper is not able to participate or fully participate in a show due to loss of, theft of, or damage to its property, Freeman shall never be liable or responsible for damages identified by the terms (by way of example only and not in limitation of the breadth of this clause) such as the following: consequential damages, loss of use damages, loss of profits damages, business interruption damages, delay damages, special damages, collateral damages, exemplary damages, damages awarded for gross negligence, direct damages, indirect damages, damages for failure of performance, breach of contract damages, fraud damages, or any other sort of damage for tort or breach of contract. This limitation shall bind the parties:

- (a) whenever or wherever the claimed loss or damage may occur;
- (b) even though the alleged loss or damage is claimed to result from negligence, strict liability, products liability, breach of contract, breach of statute or regulation, or any other legal theory or cause, and;
- (c) even though Freeman may have been advised or be on notice of the possibility or even the probability of such damages.

Freeman makes no warranties, express or implied, and expressly disclaims any and all warranties. Except for Freeman's failure to deliver in accordance with the Guaranteed Service section of the Service Guide, Freeman will not be liable for misdelivery, incomplete or otherwise inadequate delivery (including but not limited to failure to follow Shipper or Consignee instructions or failure to collect or properly deliver a payment instrument), non-delivery, missed pickup, delay on International shipments, loss or damage unless caused by Freeman's sole negligence.

### 7. SHIPPER'S RESPONSIBILITIES AND INDEMNIFICATION:

(a) Shipper must pay in full for the services rendered under this Contract at the time the services are requested. The existence of a dispute between Shipper and Freeman relative to any claim or other matter shall have no bearing on this duty of payment. No claim submitted by or on behalf of Shipper will be processed unless Shipper's account is current.

(b) Shipper understands and acknowledges that Freeman does not accept or transport illegal, dangerous or hazardous materials of any kind or nature. Shipper warrants and ensures that its property is inert, and contains no Hazardous Substances, Hazardous Materials, Chemicals, Gases, Explosives, Radioactive Materials, Biologically hazardous agents, or any other substance, matter or object in any form that could pose a threat to the health or safety of persons, property or the public welfare in general. Such goods may be warehoused at owner's risk and expense or destroyed without compensation.

(c) Shipper shall defend and indemnify Freeman, its employees, directors, officers, and agents from and against any and all demands, claims, causes of action, fines, penalties, damages (including consequential), liabilities, judgments, and expenses (including but not limited to reasonable attorneys' fees and investigation costs) on account of personal injury, death, or damage to or loss of property or profits arising out of or contributed to by any of the following: Shipper's negligence, willful misconduct, or deliberate act; Shipper's violation of Federal, State, County or Local ordinances; Shipper's violation of Show Regulations and/or Rules as published and set forth by Facility and/or Show Management; and/or Shipper's failure to comply with (b) of this Agreement regarding the inclusion of any dangerous substances in the property placed with Freeman.

**8. CLAIMS:** Shipper, Consignee, or any other party claiming an interest in the shipment must notify Freeman immediately upon delivery, or in the case of loss or damage which could not have been noted at the time of delivery, within fourteen (14) days of delivery, of any loss or damage to the shipment. Receipt of the shipment by the Consignee or the Consignee's agent without written notice on the delivery receipt and/or delivery manifest will be prima facie evidence that the shipment was delivered in good condition. The amount of the claim may not be deducted from the transportation charges. Notice of loss or damage MUST be reported to Freeman at 800-995-3579. The shipment, its container(s), and packing material must be made available to Freeman for inspection at the delivery location. All shipments are subject to opening for inspection by Freeman; however, Freeman is not obligated to perform such inspection. All claims for loss or damage MUST be made in writing to Freeman within one hundred and twenty (120) calendar days after the date of acceptance of the shipment by Freeman. Please refer to the Service Guide for claim procedures. All claims for service failure must be made within thirty (30) calendar days from the date of shipment and Freeman's sole liability for such claims arising from Guaranteed Service shipments shall be limited to the transportation charges as provided in the Guaranteed Service section of the Service Guide. All claims for overcharge must be made in writing to Freeman within sixty (60) calendar days after the invoice date. No action for loss or damage may be maintained against Freeman unless (a) claimant complies with all requirements of this section and (b) for domestic shipments, if the claimant commences the action within one (1) year of the shipment by Freeman unless otherwise required by International, Federal or State Law. If the claim is for loss or damage involving International shipments, claimant must commence the action within two (2) years from the date of acceptance of the shipment by Freeman unless otherwise required by International, Federal or State Law. For purposes of this section, no action shall be deemed to have commenced until receipt by Freeman of service of process of the action on Freeman. Claims for loss or damage must be delivered to the following address: Sedgwick, PO Box 14151, Lexington, KY 40512-4151.

**9. CHOICE OF FORUM:** THIS CONTRACT SHALL BE CONSTRUED UNDER THE LAWS OF THE UNITED STATES [INCLUDING ADOPTED INTERNATIONAL CONVENTIONS] AND THE STATE OF TEXAS WITHOUT GIVING EFFECT TO THE STATE'S CONFLICT OF LAWS RULES. FREEMAN AND SHIPPER AGREE THAT ANY CLAIM OR DISPUTE OF ANY SORT ARISING OUT OF OR IN ANY WAY RELATED TO THIS CONTRACT, ITS PERFORMANCE OR NONPERFORMANCE, OR DAMAGES ALLEGEDLY RESULTING FROM SAME WILL BE ARBITRATED IN THE CITY OF DALLAS, TEXAS, AND THE RULES OF THE AMERICAN ARBITRATION ASSOCIATION WILL APPLY. IF BINDING ARBITRATION IS UNAVAILABLE TO RESOLVE ANY CONTROVERSY AND IT IS NECESSARY TO LITIGATE THE DISPUTE, THE DISPUTE SHALL BE LITIGATED IN A COURT OF COMPETENT JURISDICTION IN DALLAS COUNTY, TEXAS.

**10. MISCELLANEOUS:** Shipper warrants the accuracy of the weight and dimension data furnished in this Contract. Shipper understands that once its property is shipped by Freeman pursuant to the instructions contained in this Contract, Shipper has no right to control the shipment; stop the shipment in transit, or divert or reschedule same, and that Shipper will have no control over the property until it is delivered pursuant to the instructions in this Contract. Shipper agrees that this Contract may be provided to any third party, including common or contract carriers of cargo by air, water, rail, or road, for the purpose of confirming the right of Freeman to control the handling of the property and all matters related to payment for the shipment.



# MOTOR CARGO

## MOTOR CARGO SERVICE REQUEST AND SHIPPING INSTRUCTIONS CONTRACT

This Contract establishes your legal obligations with regard to the property described herein being shipped with Freeman Transportation. It specifically limits your rights and possible recovery if your property is lost or damaged. You must accept all terms and conditions of this Contract. You confirm that you have read and agree with all the terms and conditions of this Contract by receipt without contest. This Contract may not be waived or varied, except in writing, and then only by an authorized representative of Freeman.

1. **DEFINITIONS.** In this Contract, "Freeman" means Freeman Expositions, Inc., and its respective employees, officers, directors, agents, assigns, affiliated companies, and related entities including any contractors appointed by Freeman. The term "Shipper" means the person or business for whom the property is being transported, and includes their respective employees, officers, directors, agents, assigns, affiliated companies, and contractors appointed by the Shipper, excluding only Freeman. "Property" is all objects of any type received from the Shipper for transport by Freeman as described herein. "Consignee" is the party to whom Shipper has designated the goods are to be delivered.

2. **FINAL CONTRACT BETWEEN THE PARTIES.** In exchange for Shipper's payments and Freeman's services, which the parties have specified in this Contract, Freeman and Shipper each agree that this Contract shall govern their respective rights and obligations regarding transportation of Shipper's property. This Contract shall take effect when the property first comes into the physical possession of Freeman for inbound shipments and after loading on the applicable carrier for outbound shipments, and the responsibility of Freeman under same shall end when the property has been placed in the possession of the Consignee or the Consignee's designated agent. If any part or provision of this Contract is found by a court of competent jurisdiction to be void or unenforceable, the remainder of the Contract shall continue in full force and effect.

3. **FREEMAN'S RESPONSIBILITIES UNDER THE CONTRACT ARE LIMITED.** Freeman shall not be responsible for the performance of individuals or firms who are not under the direct supervision or control of Freeman. Freeman shall not be responsible for events or causes of loss, delay, or damage beyond its reasonable control, including (by way of illustration only, and not as a limitation on the breadth of this clause), strike, lockout, work slowdown or stoppage, power failure, breakdown of plant or machinery, facility failure, vandalism, theft, Act of God, effect of natural elements, riot, civil commotion or disturbance, terrorism, act of war or belligerent parties, and any other cause or causes beyond the reasonable control of Freeman. Freeman shall not be liable for delay caused by highway obstructions, or faulty or impassable highways, or lack of capacity of any highway, bridge, or ferry, or caused by breakdown or mechanical defects of vehicles or equipment, or from any cause other than the negligence of Freeman. Freeman shall not be bound to transport by any particular schedule, means, vehicle or otherwise, other than with reasonable dispatch.

4. **PACKAGING AND CRATES.** Shipper's property must be well packaged for safe and secure handling, storage and shipment using ordinary care. Freeman makes neither representation nor any warranty regarding the acceptability or suitability of any packaging system or procedure that Shipper might use for its property. Freeman shall not be responsible for damage to loose or uncrated materials, padwrapped or shrink-wrapped materials, glass breakage, concealed damage, carpets in bags or poly, or improperly packed or labeled materials. Crates and packaging should be of a design to adequately protect contents for handling by forklift and similar means. General guidance as to acceptable packaging systems and procedures may be found in publications such as the National Motor Freight Classification, published by the National Motor Freight Traffic Association.

5. **PERISHABLE GOODS.** Goods of a perishable nature are carried in dry trailers without environmental or atmospheric control or other special services unless Shipper states on the face of the "Service Request and Shipping Instructions" that the goods are to be carried in a refrigerated, heated, specially ventilated or otherwise specially equipped trailer. This carriage may be subject to additional charges. Shipper is responsible for bringing the goods to the proper temperature before loading the goods into the trailer, for the proper stowage of the goods within the trailer, and for setting the temperature (including maintenance and repair), during all times after the trailer is spotted by Freeman and before the trailer is received by Freeman. Freeman is not responsible for product deterioration caused by inherent vice, defects in the merchandise or transit times in excess of product shelf life. Refrigerated, heated, specially ventilated or otherwise specially equipped trailers are not equipped to change the temperature of goods (they are equipped only to maintain temperature). Shipper will give written notice of requested temperature setting of the thermostatic controls before receipt of the goods by Freeman. When a loaded trailer is received, Freeman will verify that the thermostatic controls are set to maintain trailer temperature as requested. Freeman is unable to determine whether the goods were at the proper temperature when they were loaded into the trailer or when the trailer is delivered to Freeman. Air temperature at the unit sensor will be maintained within a proper range of plus or minus 5 degrees Fahrenheit of the temperature requested by Shipper on the face of the "Service Request and Shipping Instructions" if the goods were at that temperature when loaded into the container and if the temperature controls were properly set when the container was loaded.

6. **REFUSED SHIPMENTS.** If the Consignee refuses a shipment tendered for delivery or if Freeman is unable to deliver a shipment because of fault or mistake of Freeman, Freeman's liability shall then become that of a warehouseman.

(a) Freeman shall promptly attempt to provide notice, by telephonic, electronic or written communication as provided on the face of these shipping instructions, if so indicated, to Shipper or the party, if any, designated in these instructions to receive notice.

(b) Storage charges, if applicable, shall start no sooner than the next business day following the attempted notification. Storage may be, at Freeman's option, in any location that provides reasonable protection against loss or damage. Freeman may place the shipment in public storage at the owner's expense and without liability to Freeman.

(c) If Freeman does not receive disposition instructions within 48 hours of the time of Freeman's attempted first notification, Freeman will attempt to issue a second and final confirmed notification. Such notice shall advise that if Freeman does not receive disposition instructions within 10 days of that notification, Freeman may offer the shipment for sale at a public auction and Freeman has the right to offer the shipment for sale. The amount of sale will be applied to Freeman's invoice for transportation, storage and other lawful charges. Shipper will be responsible for the balance of charges not covered by the sale of the goods. If there is a balance remaining after all charges and expenses are paid, such balance will be paid to the owner of the property sold hereunder, upon claim and proof of ownership.

(d) Where Freeman has attempted to follow the procedure set forth above and the procedure is not possible, nothing shall be construed to abridge the right of Freeman, at its option, to sell the property under such circumstances and in such manner as may be authorized by law.

(e) When perishable goods cannot be delivered and disposition is not given within a reasonable time, Freeman may dispose of property to the best advantage. When Freeman is directed by Consignee or Consignor to unload or deliver property at a particular location where Consignor, Consignee, or the Agent of either is not regularly located, Freeman's liability for the shipment shall terminate after unloading or delivery.

7. **INSURANCE. Freeman IS NOT AN INSURER.** Shipper is responsible for obtaining insurance for its property. Freeman provides no insurance for Shipper or its property.

(THE "FAIR MARKET VALUE" EQUALS THE AS IS WHERE IS PRICE FOR THE PROPERTY AT THE LOCATION OF THE SHOW TO WHICH PRICE A WILLING BUYER AND A WILLING SELLER WOULD AGREE IN AN ORDINARY COURSE OF BUSINESS, ARM'S LENGTH SALE, OR \$25.00 (USD) PER POUND OF CARGO LOST OR DAMAGED UNLESS AT THE TIME OF SHIPMENT SHIPPER MAKES A DECLARATION OF VALUE FOR CARRIAGE IN THE SPACE DESIGNATED ON THE SHIPPING INSTRUCTIONS AND PAYS THE APPROPRIATE VALUATION CHARGE. Even if Shipper has made a declaration of value, liability shall never exceed the depreciated original invoice value or the fair market value of the property, whichever is less. The value per pound for applying declared valuation charges shall be determined by dividing Shipper's declared value for carriage by the actual weight of the shipment. In all cases not prohibited by law, where a lower value than the actual value of the said property has been stated in writing by Shipper or has been agreed upon in writing as the released value of the property upon which the rate is based, such lower value plus freight charges, if paid, shall be the maximum recoverable amount for loss or damage. **Notwithstanding the above limitations, all shipments containing the following items of extraordinary value are limited to a maximum declared value of \$500.00 (USD):** (a) Artworks and objects of art, including without limitation, original paintings, drawings, etchings, watercolors, tapestries and sculptures or prototypes; (b) Clocks, jewelry, including costume jewelry, furs, and fur-trimmed clothing; (c) Personal effects, including without limitation, papers and documents; or (d) Coin money, currency, gift certificates, debit cards, credit cards, and any other items of extraordinary value. (e) For unmarked, unlabeled and improperly packaged television monitors, the maximum liability is the lesser of \$3.00 (USD) per pound or the actual invoice price.

Any declared value in excess of the maximums allowed herein is null and void, and the acceptance by Freeman for carriage of any shipment with a declared value in excess of the allowed maximums does not constitute a waiver of these maximums. In any event, (excluding small package program shipments) **Freeman's MAXIMUM LIABILITY WILL NEVER BE MORE THAN \$100,000 PER SHIPMENT.** Shipper understands that even if Shipper is not able to participate or fully participate in a Show due to loss of, theft of, or damage to their property, Freeman shall not be liable or responsible for damages identified by the terms (by way of example only and not in limitation of the breadth of this clause) such as the following: consequential damages, loss of use damages, loss of profits damages, business interruption damages, delay damages, special damages, collateral damages, exemplary damages, damages awarded for gross negligence, direct damages, indirect damages, or damages for failure of performance, breach of contract damages, fraud damages, or any other sort of damage for tort or breach of contract. This limitation shall bind the parties: (a) **WHENEVER OR WHEREVER THE CLAIMED LOSS OR DAMAGE MAY OCCUR;** (b) **EVEN THOUGH THE ALLEGED LOSS OR DAMAGE IS CLAIMED TO RESULT FROM NEGLIGENCE, STRICT LIABILITY, PRODUCTS LIABILITY, BREACH OF CONTRACT, BREACH OF STATUTE OR REGULATION, OR ANY OTHER LEGAL THEORY OR CAUSE, AND;** (c) **EVEN THOUGH FREEMAN MAY HAVE BEEN ADVISED OR BE ON NOTICE OF THE POSSIBILITY OR EVEN THE PROBABILITY OF SUCH DAMAGES.**

### 8. SHIPPER'S RESPONSIBILITIES AND INDEMNIFICATION:

(a) Shipper must pay in full for the services rendered under this Agreement at the time the services are requested. The existence of a dispute between Shipper and Freeman relative to any claim or other matter shall have no bearing on this duty of payment. No claim may be submitted by or on behalf of Shipper to Freeman unless Shipper's account is current.

(b) Shipper understands and acknowledges that Freeman does not accept or transport illegal or hazardous materials of any kind or nature. Shipper warrants and will ensure that its property is inert, and contains no Hazardous Substances, Hazardous Materials, Chemicals, Gases, Explosives, Radioactive Materials, Biologically hazardous agents, or any other substance, matter or object in any form that could pose a threat to the health or safety of Freeman persons, property, or the public welfare in general. Such goods may be warehoused at owner's risk and expense or destroyed without compensation.

(c) Shipper shall defend and indemnify Freeman, its employees, directors, officers, and agents from and against any and all demands, claims, causes of action, fines, penalties, damages (including consequential), liabilities, judgments, and expenses (including but not limited to reasonable attorneys' fees and investigation costs) on account of personal injury, death, or damage to or loss of property or profits arising out of or contributed to by any of the following: Shipper's negligence, willful misconduct, or deliberate act; Shipper's violation of Federal, State, County or Local ordinances; Shipper's violation of Show Regulations and/or Rules as published and set forth by Facility and/or Show Management; and/or Shipper's failure to comply with subsection (b) of this section regarding the inclusion of any dangerous substances in the property placed with Freeman.

9. **CLAIMS.** Claims must be filed in writing within nine (9) months after the date of delivery of the property (or in the case of export traffic, within nine (9) months after delivery at the port of export), except that claims for failure to make delivery must be filed within nine (9) months after a reasonable time for delivery has elapsed. Suits for loss, damage, or delay shall be instituted against Freeman no later than two (2) years and one (1) day from the day when written notice is given by Freeman to the claimant that Freeman has disallowed the claim or any part or parts of the claim specified in the notice. Shipper shall deliver notice of claim for loss or damage by hand, U.S. mail, courier, facsimile, or electronic means to Sedgwick, PO Box 14151, Lexington, KY 40512-4151 as soon as loss or damage is discovered. The notice of claim shall invite a prompt joint survey of the damage, at a time and place to be agreed between the parties, and such survey shall go forward promptly. However, if in any case the property is received by the Consignee or the Consignee's agent without notice of loss or damage to property being served on Freeman within 15 calendar days of the receipt of the property, it is agreed between Freeman and Shipper that in that instance the presumption shall arise that the property was delivered in proper quantity and in good condition. Claims filed more than nine (9) months following the date on which the property was delivered or should have been delivered are agreed to be forever time barred.

10. **CHOICE OF FORUM / ARBITRATION.** THIS CONTRACT SHALL BE CONSTRUED UNDER THE LAWS OF THE STATE OF TEXAS WITHOUT GIVING EFFECT TO ITS CONFLICT OF LAWS RULES. EXCLUSIVE VENUE FOR ALL DISPUTES ARISING OUT OF CONTRACT, TORT, COMMON LAW OR RELATING TO THE ENFORCEMENT OR INTERPRETATION OF THIS CONTRACT SHALL RESIDE IN A COURT OF COMPETENT JURISDICTION IN DALLAS COUNTY, TEXAS. Notwithstanding anything herein to the contrary, any controversy or claim arising out of or relating to this Agreement, or the breach thereof, shall be exclusively settled by arbitration administered by the American Arbitration Association in accordance with its Commercial Arbitration Rules and judgment on the award rendered by the arbitrator(s) may be entered by any court having jurisdiction thereof.

11. **MISCELLANEOUS.** (a) Shipper warrants the accuracy of the weight and dimension data furnished in this Contract. (b) Shipper understands that once its property is shipped by Freeman pursuant to the instructions contained in this Contract, Shipper has no right to control the shipment, stop the shipment in transit, or divert or reschedule same. (c) Shipper agrees that this Contract may be provided to any third party, including common or contract carriers of cargo by air, water, rail, or road, for the purpose of confirming the right of Freeman to control the handling of the property and all matters related to payment for the shipment. Shipper agrees that all shipments are subject to correction and final charges determined by the actual or re-weighed weight of the shipment.

12. **SMALL PACKAGE PROGRAM.** If items shipped via Freeman's Small Packages program are lost, damaged or destroyed while in Freeman's possession, **FREEMAN'S MAXIMUM LIABILITY SHALL BE \$100 per package UNLESS AT THE TIME OF SHIPMENT SHIPPER MAKES A DECLARATION OF VALUE IN THE SPACE DESIGNATED ON THE SHIPPING INSTRUCTIONS AND PAYS THE APPROPRIATE VALUATION CHARGE.** If small packages are received by the Shipper and notice of loss or damage is not received by Freeman within 15 days of the delivery of the property, the parties agree that the presumption shall arise that the property was delivered in proper quantity and in good condition.

# WHAT ARE FREIGHT SERVICES?

As the official service contractor, Freeman is the exclusive provider of freight services. Material handling includes unloading your exhibit material, storing up to 30 days in advance at the warehouse address, delivering to the booth, the handling of empty containers to and from storage, and removing of material from the booth for reloading onto outbound carriers. It should not be confused with the cost to transport your exhibit material to and from the convention or event. You have two options for shipping your advance freight — either to the warehouse or directly to show site.

## How do I ship to the warehouse?

- We will accept freight beginning 30 days prior to show move-in.
- To check on your freight arrival, call Exhibitor Services at the location listed on Quick Facts.
- To ensure timely arrival of your materials at show site, freight should arrive by the deadline date listed on Quick Facts. Your freight will still be received after the deadline date, but additional charges will be incurred.
- The warehouse will receive shipments Monday through Friday, except holidays. Refer to Quick Facts for warehouse hours. No appointment is necessary.
- The warehouse will accept crates, cartons, skids, trunks/cases and carpets. Loose or pad-wrapped material must be sent directly to show site.
- All shipments must have a bill of lading or delivery slip indicating the number of pieces, type of merchandise and weight.
- Certified weight tickets must accompany all shipments.
- Warehouse freight will be delivered to the booth prior to exhibitor setup.
- Please call the number located on Quick Facts if you want to ship oversized material that requires special equipment to the warehouse.

## How do I ship to show site?

- Freight will be accepted only during exhibitor move-in. Please refer to Quick Facts for the specific exhibitor move-in dates and times.
- All shipments must have a bill of lading or delivery slip indicating the number of pieces, type of merchandise and weight.
- Certified weight tickets must accompany all shipments.

## What about prepaid or collect shipping charges?

- Collect shipments will be returned to the delivery carrier.
- To ensure that your freight does not arrive collect, mark your bill of lading "prepaid."
- "Prepaid" designates that the transportation charges will be paid by the exhibitor or a third party.

## How should I label my freight?

- The label should contain the exhibiting company name, the booth number and the name of the event.
- The specific shipping address for either the warehouse or show site is located on Quick Facts.

## How do I estimate my Material Handling charges?

- Charges will be based on the weight of your shipment. Each shipment received is considered separately. The shipment weight will be rounded to the next 100 pounds. Each 100 pounds is considered one "cwt." (one hundred weight). All shipments are subject to reweigh.
- On the Order Form, select whether the freight will arrive at the warehouse or be sent directly to show site.
- Next, select the category that best describes your shipment. There are three categories of freight:

**Crated:** material that is skidded or is in any type of shipping container that can be unloaded at the dock with no additional handling required.

**Special Handling:** material delivered by the carrier in such a manner that it requires additional handling, such as ground unloading, stacked and constricted space unloading, designated piece unloading, loads mixed with pad-wrapped material, loads failing to maintain shipping integrity, carpet and/or pad-only shipments, and shipments that require additional time, equipment or labor to unload. Federal Express and UPS are included in this category due to their delivery procedures.

**Uncrated:** material that is shipped loose or pad-wrapped, and/or unskidded machinery without proper lifting bars or hooks.

- Add overtime charges for inbound if material is delivered to the booth during the overtime period stated on Quick Facts. This includes both warehouse and show-site shipments.

- Add overtime charges for outbound if material is loaded onto the outbound carrier during the overtime period stated on Quick Facts.
- Add the late delivery charge listed on the Order Form if the shipment is accepted at the warehouse or at show site after the deadline date listed on Quick Facts.
- The above services, whether used completely or in part, are offered as a package and the charges will be based on the total inbound weight of the shipment.
- Shipments received without receipts or freight bills, such as UPS and Federal Express, will be delivered to the booth without guarantee of piece count or condition.

## What happens to my empty containers during the show?

- Pick up "Empty Labels" at the Service Center. Place a label on each container. Labeled containers will be picked up periodically and stored in non-accessible storage during the show.
- At the close of the show, the empty containers will be returned to the booth in random order. Depending on the size of the show, this process may take several hours.

## How do I protect my materials after they are delivered to the show or before they are picked up after the show?

- Consistent with trade show industry practices, there may be a lapse of time between the delivery of your shipment(s) to your booth and your arrival. The same is true for the outbound phase of the show — the time between your departure and the actual pick-up of your materials. During these times, your materials will be left unattended. We recommend that you arrange for a representative to stay with your materials or that you hire security services to safeguard your materials.

## How do I ship my materials after the close of the show?

- Each shipment must have a completed Material Handling Agreement in order to ship materials from the show. All pieces must be labeled individually.
- To save time, complete and submit the Outbound Shipping Form in advance, or you may contact the Service Center at show site for your shipping documents. The Material Handling Agreement and labels will be processed and available prior to show closing.
- After materials are packed, labeled, and ready to be shipped, the completed Material Handling Agreement must be turned in at the Service Center.
- Call your designated carrier with pick-up information. Please refer to Quick Facts for specific dates and times. In the event your selected carrier fails to show on final move-out day, your shipment will either be rerouted to Freeman's carrier choice or delivered back to the warehouse at exhibitor's expense.
- For your convenience, show-recommended carriers will be on site to handle outbound transportation.

## Where do I get a forklift?

- Forklift orders to install or dismantle your booth after materials are delivered may be ordered in advance or at show site. We recommend that you order in advance to avoid additional charges at show site. Refer to the Order Form for available equipment.
- Advance and show-site orders for equipment and labor will be dispatched once a company representative signs the labor order at the Service Center.
- Start time is guaranteed only when equipment is requested for the start of the working day.

## Do I need insurance?

- Be sure your materials are insured from the time they leave your firm until they are returned after the show. It is suggested that exhibitors arrange all-risk coverage. This can be done by riders to your existing policies.
- All materials handled by Freeman are subject to the enclosed Terms and Conditions.

## Other available services (may not be available in all locations)

- Cranes
- Scissor lifts, condors
- Access storage at show site
- Exhibit transportation services (see enclosed brochure)
- Security storage at show site
- Short-term and long-term warehouse storage
- Local pick-up and delivery
- Priority empty return

# F R E E M A N

# F R E E M A N

9258 Park South View, Suite 100  
Houston, Texas 77051  
Ph: 713-770-6750 • Fax: 469-621-5613  
FreemanHoustonES@freemanco.com

INCLUDE THE FREEMAN METHOD OF PAYMENT FORM WITH YOUR ORDER

NAME OF SHOW: **UH CT BAUER COLLEGE OF BUSINESS CAREER FAIR / SEPT 25, 2015**

COMPANY NAME \_\_\_\_\_ BOOTH #: \_\_\_\_\_

CONTACT NAME: \_\_\_\_\_ PHONE #: \_\_\_\_\_

E-MAIL ADDRESS \_\_\_\_\_

For Assistance, please call 713-770-6750 to speak with one of our experts.

Let Freeman OnLine<sup>®</sup> estimate your material handling charges for you. Log on to [www.freemanco.com/store](http://www.freemanco.com/store), select your show and click on "Estimate My Material Handling Costs". From Freeman OnLine<sup>®</sup> you can print extra shipping labels, get tips on how to package your freight and much more.

## MATERIAL HANDLING SERVICES

- CRATED:** Material that is skidded or is in any type of shipping container that can be unloaded at the dock with no additional handling required.
- SPECIAL HANDLING:** Material delivered in such a manner that it requires additional handling, such as ground unloading, stacked or constricted space unloading, designated piece unloading, shipment integrity, alternate delivery location, loads mixed with pad wrapped material, no documentation and shipments that require additional time, equipment or labor to unload. **Federal Express, UPS & DHL** are included in this category due to their delivery procedures.  
(See definitions on back)
- UNCRAVED:** Material that is shipped loose or pad-wrapped, and/or unskidded machinery without proper lifting points.
- CARPET AND/OR PAD ONLY:** Shipments that consist of loose carpet and/or padding only require additional labor and equipment to unload.
- STRAIGHT TIME:** 8:00 A.M. to 4:30 P.M. Monday through Friday
- OVERTIME:** 4:30 P.M. to 8:00 A.M. Monday through Friday, all day Saturday, Sunday, and Holidays  
(Overtime will be applied to all freight received at the warehouse and/or show site that must be moved into or out of booth during above listed times.)

Description	Price Per CWT	200 lb. Minimum
-------------	---------------	-----------------

**RATE CLASSIFICATIONS:**

<b>Warehouse Shipment (200 lb. minimum)</b>		
Crated or Skidded Shipment.....	\$ 67.00	134.00
Special Handling Shipment.....	\$ 87.25	174.50
Carpet and/or Pad Only Shipment.....	\$100.50	201.00
<b>Show Site Shipment (200 lb. minimum)</b>		
Crated or Skidded Shipment.....	\$ 71.00	142.00
Special Handling Shipment.....	\$ 92.50	185.00
Uncrated or Pad Wrapped Shipment.....	\$106.50	213.00
Carpet and/or Pad Only Shipment.....	\$106.50	213.00
<b>Small Package - Maximum weight is 30 lbs per shipment*</b>		
Per Shipment .....	\$ 40.00	

\*A small package shipment is a shipment totaling any number of pieces with a combined weight not to exceed 30 lbs that is received on the same day, from the same shipper and delivered by the same carrier.

**ADDITIONAL SURCHARGES:**

<b>Shipment Delivered after Deadline Date (in addition to above rates)</b>		
Warehouse Shipment after Deadline .....	\$ 16.75	33.50
Show Site Shipment after Deadline .....	\$ 17.75	35.50
<b>Overtime Charge - Inbound (in addition to above rates)</b>		
Crated or Skidded Shipment.....	\$ 17.75	35.50
Special Handling Shipment.....	\$ 23.25	46.50
Uncrated or Pad Wrapped Shipment .....	\$ 26.75	53.50
Carpet and/or Pad Only Shipment.....	\$ 26.75	53.50
<b>Overtime Charge - Outbound (in addition to above rates)</b>		
Crated or skidded Shipment .....	\$ 17.75	35.50
Special Handling Shipment.....	\$ 23.25	46.50
Uncrated or Pad Wrapped Shipment .....	\$ 26.75	53.50
Carpet and/or Pad Only Shipment.....	\$ 26.75	53.50
<b>Mobile Spotting Fee</b> .....		\$250.00

Description	Weight	CWT	Price per CWT	Estimated Total Cost (200 lb. Min.)
	÷ 100 =			
<b>Surcharges</b>	÷ 100 =			
			<b>Tax</b>	<b>n/a</b>
			<b>Total</b>	

**FREEMAN material handling**

## SPECIAL HANDLING DEFINITIONS

for frequently asked questions and material handling estimator tools, go to [www.myfreemanonline.com](http://www.myfreemanonline.com)

Special handling applies to shipments that are loaded by cubic space and/or packed in such a manner as to require additional labor/handling, such as ground unloading, constricted space unloading, designated piece unloading, carpet/pad only shipments or stacked shipments. Also included are shipment integrity, alternate delivery locations, mixed shipments, and shipments without individual bills of lading. Shipments loaded in this manner require additional time, labor, or equipment, to unload, sort and deliver.

**What is Ground Loading/Unloading?**

Vehicles that are not dock height, preventing the use of loading docks, such as U-hauls, flat bed trailers, double drop trailers, company vehicles with trailers that are not dock level, etc.

**What is Constricted Space Loading/Unloading?**

Trailer loaded "high and tight" shipments that are not easily accessible. Freight is loaded to full capacity of trailer – top to bottom, side to side. One example of this is freight that is loaded down one side of a trailer that must be bypassed to reach targeted freight.

**What is Designated Piece Loading/Unloading?**

Drivers that require the loading crew to bring multiple pieces of the freight to the rear of the trailer to select the next piece, having to remove freight from the trailer then reload to fit or the trailer must be loaded in a sequence to ensure all items fit.

**What are Stacked Shipments?**

Shipments loaded in such a manner requiring multiple items to be removed to ground level for delivery to booth. Stacked or "cubed out" shipments, loose items placed on top of crates and/or pallets constitute special handling.

**What is Shipment Integrity?**

Shipment integrity involves shipments on a carrier that are intermingled, or delivered in such a manner that additional labor is needed to sort through and separate the various shipments on a truck for delivery to our customers.

**What is Alternate Delivery Location?**

Alternative delivery location refers to shipments that are delivered by a carrier that requires us to deliver some shipments to different levels in the same building, or to other buildings in the same facility.

**What are Mixed Shipments?**

Mixed shipments are defined as shipments of mixed crated and uncrated goods, where the percentage of uncrated is minimal and does not warrant the full uncrated rate for the shipment, but does require special handling. Freeman defines special handling for mixed loads as having less than 50% of the volume as uncrated.

**What does it mean if I have "No Documentation"?**

Shipments arrive from a small package carrier (including, among others, Federal Express, UPS, Airborne Express & DHL) without an individual Bill of Lading, requiring additional time, labor and equipment to process.

**What about carpet only shipments?**

Shipments that consist of carpet and/or carpet padding only require special handling because of additional labor and equipment to unload.

**What is the difference between Crated and Uncrated Shipments?**

Crated shipments are those that are packed in any type of shipping container that can be unloaded at the dock with no additional handling required. Such containers include crates, fiber cases, cartons, and properly packed skids. An uncrated shipment is material that is shipped loose or pad-wrapped, and/or unskidded without proper lifting bars and hooks.

# F R E E M A N

9258 Park South View, Ste 100  
Houston, TX 77051  
(713) 770-6750 Fax: (469) 621-5613  
FreemanHoustonES@freemanco.com

OUTBOUND MATERIAL HANDLING  
AND SHIPPING LABELS

NAME OF SHOW: **UH CT BAUER COLLEGE OF BUSINESS CAREER FAIR / SEPT 25, 2015**

COMPANY NAME: \_\_\_\_\_ BOOTH #: \_\_\_\_\_ BOOTH SIZE: \_\_\_\_\_ X

CONTACT NAME : \_\_\_\_\_ PHONE #: \_\_\_\_\_

E-MAIL ADDRESS : \_\_\_\_\_

For Assistance, please call (713) 770-6750 to speak with one of our experts.

For fast, easy ordering, go to [www.freemanco.com/store](http://www.freemanco.com/store)

EVERY OUTBOUND SHIPMENT WILL REQUIRE A MATERIAL HANDLING AGREEMENT AND LABELS. WE WOULD BE HAPPY TO PREPARE THESE FOR YOU IN ADVANCE AND WILL DELIVER THEM TO YOUR BOOTH AT SHOW SITE TO REVIEW AND SIGN. TO TAKE ADVANTAGE OF THIS SERVICE, PLEASE COMPLETE AND RETURN THIS FORM.

## SHIPPING INFORMATION

**FROM:** SHIPPER/EXHIBITOR NAME: \_\_\_\_\_

BILLING ADDRESS: \_\_\_\_\_

CITY: \_\_\_\_\_ STATE/ PROVINCE: \_\_\_\_\_ ZIP/ POSTAL CODE: \_\_\_\_\_

**SHIP TO:** COMPANY NAME: \_\_\_\_\_

DELIVERY ADDRESS: \_\_\_\_\_

CITY: \_\_\_\_\_ STATE/ PROVINCE: \_\_\_\_\_ ZIP/ POSTAL CODE: \_\_\_\_\_

PHONE#: \_\_\_\_\_ ATTN: \_\_\_\_\_

SPECIAL INSTRUCTIONS: \_\_\_\_\_

## METHOD OF SHIPMENT

PLEASE CHECK DESIRED METHOD OF SHIPMENT BELOW

### FREEMAN EXHIBIT TRANSPORTATION

- 1 Day: Delivery next business day
- 2 Day: Delivery by 5:00 P.M. second business day
- Expedited
- Deferred: Delivery within 3-4 business days
- Standard Ground
- Specialized: Pad wrapped, uncrated, or truckload
- OTHER COMMON CARRIER \_\_\_\_\_
- OTHER VAN LINE \_\_\_\_\_
- OTHER AIR FREIGHT \_\_\_\_\_
  - Next Day
  - 2nd Day
  - Deferred

CARRIER PHONE #: \_\_\_\_\_

Once your shipment is packed and ready to be picked up, please return the Material Handling Agreement to the Exhibitor Services Center.

Verify the piece count, weight and that a signature is on the Material Handling Agreement prior to shipping out.

SHIPMENTS WITHOUT PAPERWORK TURNED IN WILL BE RETURNED TO OUR WAREHOUSE AT EXHIBITOR'S EXPENSE.

Freeman will make arrangements for all Freeman Exhibit Transportation shipments. Arrangements for pick-up by other carriers is the responsibility of the exhibitor.

**DESIRED NUMBER OF LABELS:** \_\_\_\_\_

**F R E E M A N**

**R U S H**

**DO NOT DELAY**

**F R E E M A N**

**R U S H**

**DO NOT DELAY**

**RECEIVING DATE BEGINS: AUGUST 28, 2015**

**RECEIVING DATE BEGINS: AUGUST 28, 2015**

**DEADLINE DATE IS: SEPTEMBER 21, 2015**

**DEADLINE DATE IS: SEPTEMBER 21, 2015**

**TO:** \_\_\_\_\_

*EXHIBITOR NAME*

**TO:** \_\_\_\_\_

*EXHIBITOR NAME*

**C/O: FREEMAN**

**9258 PARK SOUTH VIEW**

**STE 100**

**HOUSTON, TX 77051**

**C/O: FREEMAN**

**9258 PARK SOUTH VIEW**

**STE 100**

**HOUSTON, TX 77051**

**WAREHOUSE**

**UH CT BAUER COLLEGE OF BUSINESS**

**EVENT: CAREER FAIR**

**WAREHOUSE**

**UH CT BAUER COLLEGE OF BUSINESS**

**EVENT: CAREER FAIR**

**BOOTH NO: \_\_\_\_\_ NO. \_\_\_\_\_ OF \_\_\_\_\_ PCS**

**BOOTH NO: \_\_\_\_\_ NO. \_\_\_\_\_ OF \_\_\_\_\_ PCS**

THE ABOVE LABELS ARE PROVIDED FOR YOUR CONVENIENCE.  
PLACE ONE ON EACH PIECE SHIPPED TO ENSURE PROPER DELIVERY.  
IF MORE LABELS ARE NEEDED, COPIES ARE ACCEPTABLE.



**F R E E M A N**

**F R E E M A N**

**R U S H**

**R U S H**

**DO NOT DELAY**

**DO NOT DELAY**

**CANNOT DELIVER BEFORE SEPTEMBER 25, 2015**

**CANNOT DELIVER BEFORE SEPTEMBER 25, 2015**

TO: \_\_\_\_\_  
*EXHIBITOR NAME*

TO: \_\_\_\_\_  
*EXHIBITOR NAME*

**C/O: FREEMAN**  
**HILTON UNIV OF HOUSTON**  
**4800 CALHOUN**  
**CONRAD, SHAMROCK, WALDORF**  
**BALLROOMS**  
**HOUSTON, TX 77204**

**C/O: FREEMAN**  
**HILTON UNIV OF HOUSTON**  
**4800 CALHOUN**  
**CONRAD, SHAMROCK, WALDORF**  
**BALLROOMS**  
**HOUSTON, TX 77204**

**SHOW SITE**

**SHOW SITE**

**UH CT BAUER COLLEGE OF BUSINESS**

**UH CT BAUER COLLEGE OF BUSINESS**

**CAREER FAIR**

**CAREER FAIR**

EVENT: \_\_\_\_\_

EVENT: \_\_\_\_\_

BOOTH NO: \_\_\_\_\_ NO. \_\_\_\_\_ OF \_\_\_\_\_ PCS

BOOTH NO: \_\_\_\_\_ NO. \_\_\_\_\_ OF \_\_\_\_\_ PCS

THE ABOVE LABELS ARE PROVIDED FOR YOUR CONVENIENCE.  
PLACE ONE ON EACH PIECE SHIPPED TO ENSURE PROPER DELIVERY.  
IF MORE LABELS ARE NEEDED, COPIES ARE ACCEPTABLE.

# FURNISHING essentials 2

## seating

When it comes to basic seating needs, look no further than Freeman. Our well-designed modern chairs, armchairs and stools will serve any exhibitor's show space requirements.



soho bistro table (page 2)

### black diamond stool

22"W 18"L 46"H – N71088

### diva series

Natural blonde wood and matte chrome finish highlight this sleek Italian design.

### diva counter stool

17"W 16"L 36"H – N71092

The intermediate 25" seating height makes this stool ideal for theater or demo areas.

### diva chair

18"W 16"L 31"H – N71091

A natural complement to modern exhibit designs.



### black diamond side chair

21"W 23"L 32"H – N71089

### black diamond armchair

20"W 21"L 33"H – N71090



### gray gaslift stool

24"W 20"L 46"H

With Arms – N71048

No Arms – N71047

### gray gaslift chair

26"W 20"L 38"H

With Arms – N71046

No Arms – N71045

Telescoping height adjustment; five-caster base rolls with ease.





**limerick® stool by Herman Miller***Gray*

18"W 17.75"L 44"H – C210109

**limerick® chair by Herman Miller***Gray*

18"W 17.75"L 33"H – C210108



# tables

What Freeman always brings to the table is professionalism, and nothing says more about your meeting space and/or show site than your surfaces and tabletops. Choose from modern glass conference tables, traditional cocktail, end tables and much more.

**pedestal tables**

A range of table-top sizes and materials with pedestals in various heights to fit any space.

**soho series**

Black-Top Mini	18" Round 18"H	N72066
Black-Top Café	24" Round 30"H	N72069
Black-Top Bistro	24" Round 42"H	N72070
Black-Top Café	36" Round 30"H	N72067
Black-Top Bistro	36" Round 42"H	N72068

**chelsea series**

Butcher Block-Top Café	30" Round 30"H	N72063
	36" Round 30"H	N72064
Butcher Block-Top Bistro	30" Round 42"H	N720163
	36" Round 42"H	N720164



studio series

**black end table**

17"W 17"L 18"H – C115104

**black cocktail table**

36"W 20"L 15"H – C115103



# display

Some of the most essential elements of your exhibit are the surfaces on which you display your show materials. That's why we have an appealing variety of displays, from standing cylinders to sleek computer desks to draped tables and counters, to ensure your show space will be both attractive and interactive.

**draped or undraped table counters**

Colored draping includes white vinyl top and pleated skirt on three sides. Fourth-side draping is available. Undraped tables include white vinyl tops.



	3'	4'	6'	8'
<b>tables</b> (30" height)				
Draped	C130330	C130430	C130630	C130830
Draped on fourth side			C12404630	C12404830
Undraped	C131330	C131430	C131630	C131830
<b>counters</b> (42" height)				
Draped	C130342	C130442	C130642	C130842
Draped on fourth side			C12404642	C12404842
Undraped	C131342	C131442	C131642	C131842

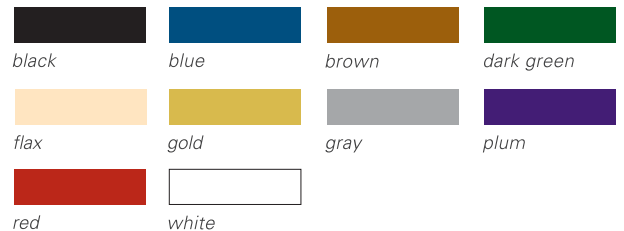

Table-top risers are also available in a variety of sizes. See order form for details.

**display cylinders**

*Black*

**low**

30"W 15"H – N75020

**medium**

18"W 20"H – N75021

**high**

24"W 36"H – N75022



**orion computer kiosk**

*Black*

28"L 28"D 40.5"H – N75079

Pedestal for computer demo with keyboard tray and interior storage. (Computer not included.)



**display cubes**

*Black*

**12" small**

12"W 12"L 42"H – N75030

**18" medium**

18"W 18"L 36"H – N75031

**24" large**

24"W 24"L 42"H – N75032



**display counter**

*Black*

24"W 49"L 42"H – N72056



# accessories

We know that every exhibit is different and requires certain pieces that may be hard to find. That's why we offer an assortment of accessories that will meet your needs, from literature racks to bulletin boards to refrigerators and file cabinets. No matter the requirement, your exhibit will always stand out with these striking and functional pieces.

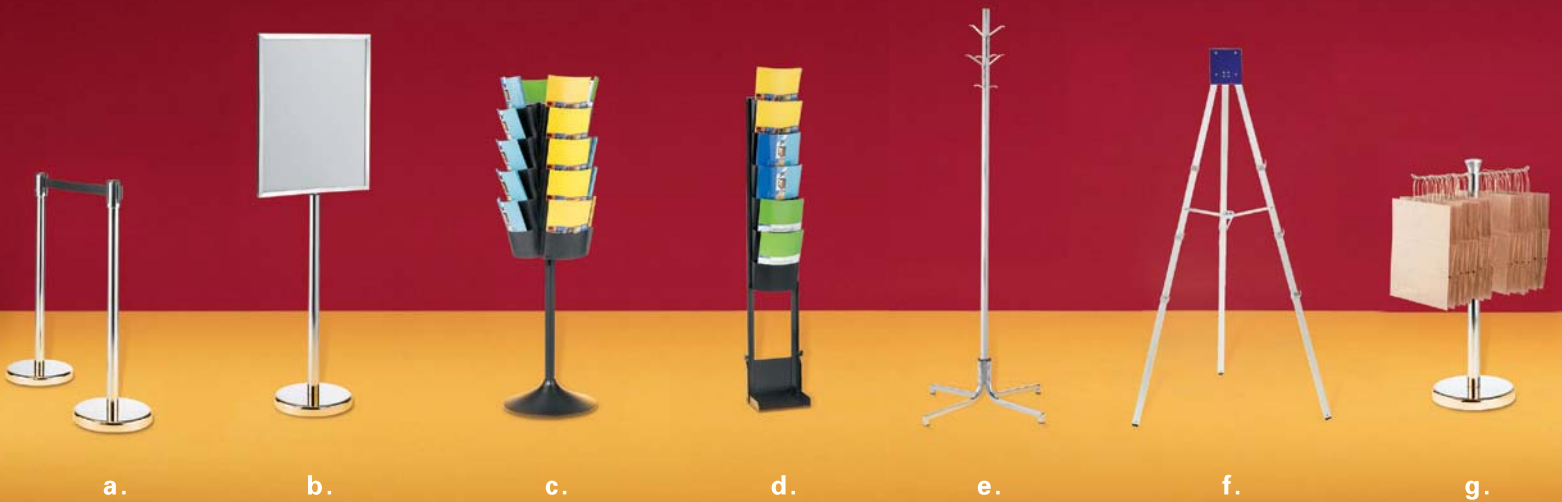

**a. chrome stanchion with 8' retractable belt**

42"H – C220121

**b. chrome sign holder**

Holds 22"x 28" sign – C220118

**c. round literature rack**

17"W 17"L 57"H – N750135

Revolving black display holds printed materials for easy access from 20 pockets.

**d. flat literature rack**

10"W 55"H – N750136

Forward-facing black display presents printed materials in six pockets.

**e. chrome coat tree**

C220109

**f. chrome easel**

C220134

**g. chrome bag rack**

C220110

**special draping**

*(not pictured)*

Special drape is available in a variety of colors. Refer to the order form for details.

## accessories

### file cabinet with lock

Standard Size

#### two-drawer

15"W 29"L 28"H – N74082

#### four-drawer

15"W 29"L 50"H – N74081



### floor-standing bulletin board

48"W 96"L 78"H – C10201484



### table lamp\*

Black

25"H – N75052



### small refrigerator\*

19"W 19"L 34"H – N75057



### wastebasket

Wastebasket color may vary.

C220107



### corrugated wastebasket

C220106



\*Note: Electrical power must be ordered separately.

# FREEMAN

9258 Park South View, Suite 100  
Houston, Texas 77051

Ph: 713-770-6750 • Fax: 469-621-5613  
FreemanHoustonES@freemanco.com

**ONLINE PRICE  
DISCOUNT PRICE  
DEADLINE DATE  
SEPTEMBER 16, 2015**

INCLUDE THE FREEMAN METHOD OF  
PAYMENT FORM WITH YOUR ORDER

NAME OF SHOW: **UH CT BAUER COLLEGE OF BUSINESS CAREER FAIR / SEPT 25, 2015**

COMPANY NAME: \_\_\_\_\_ BOOTH #: \_\_\_\_\_

CONTACT NAME: \_\_\_\_\_ PHONE #: \_\_\_\_\_

E-MAIL ADDRESS: \_\_\_\_\_

For Assistance, please call 713-770-6750 to speak with one of our experts.

For fast, easy ordering, go to [www.freemanco.com/store](http://www.freemanco.com/store)

Qty	Part #	Description	Online Price	Discount Price	Standard Price	Total
<b>PAGE 1</b>						

_____	N71088	Black Diamond Stool.....	\$134.00	\$147.40	\$187.60	_____
_____	N71089	Black Diamond Side Chair ...	\$108.25	\$119.10	\$151.55	_____
_____	N71090	Black Diamond Arm Chair ....	\$139.25	\$153.20	\$194.95	_____
_____	C115104	Studio Black End Table .....	\$79.00	\$86.90	\$110.60	_____
_____	N75079	Orion Computer Kiosk.....	\$348.25	\$383.10	\$487.55	_____

Display Cylinders						
_____	N75020	Black Display Cylinder/Low..	\$188.50	\$207.35	\$263.90	_____
_____	N75021	Black Display Cylinder/Med...	\$218.50	\$240.35	\$305.90	_____
_____	N75022	Black Display Cylinder/Lg.....	\$258.50	\$284.35	\$361.90	_____

PAGE 2						
_____	C210108	Limerick® Chair by Herman Miller .....	\$56.75	\$62.45	\$79.45	_____
_____	C210109	Limerick® Stool by Herman Miller .....	\$99.00	\$108.90	\$138.60	_____

Pedestal Tables - SoHo Series						
_____	N72066	Black-top Mini 18"W x 18"H..	\$102.50	\$112.75	\$143.50	_____
_____	N72069	Black-top Cafe 24"W x 30"H..	\$166.00	\$182.60	\$232.40	_____
_____	N72070	Black-top Bistro 24"W x 42"H	\$172.00	\$189.20	\$240.80	_____
_____	N72067	Black-top Cafe Table 36"x30"	\$170.00	\$187.00	\$238.00	_____
_____	N72068	Black-top Bistro Table 36"x42"	\$185.50	\$204.05	\$259.70	_____

Pedestal Tables - Chelsea Series - Butcher Block Top						
_____	N72063	Cafe Table 30"W x 30"H .....	\$166.00	\$182.60	\$232.40	_____
_____	N72064	Cafe Table 36"W x 30"H.....	\$166.00	\$182.60	\$232.40	_____
_____	N720163	Bistro Table 30"W x 42"H.....	\$171.50	\$188.65	\$240.10	_____
_____	N720164	Bistro Table 36"W x 42"H.....	\$171.50	\$188.65	\$240.10	_____

Qty	Part #	Description	Online Price	Discount Price	Standard Price	Total
<b>PAGE 2 (continued)</b>						

Draped Tables - Tables are 30" wide									
<input type="checkbox"/>	Black	<input type="checkbox"/>	Blue	<input type="checkbox"/>	Brown	<input type="checkbox"/>	Dark Green	<input type="checkbox"/>	Flax
<input type="checkbox"/>	Gold	<input type="checkbox"/>	Gray	<input type="checkbox"/>	Plum	<input type="checkbox"/>	Red	<input type="checkbox"/>	White

_____	C130330	Draped Table 3'L x 30"H.....	\$83.50	\$91.85	\$116.90	_____
_____	C130430	Draped Table 4'L x 30"H.....	\$97.00	\$106.70	\$135.80	_____
_____	C130630	Draped Table 6'L x 30"H.....	\$123.75	\$136.15	\$173.25	_____
_____	C130830	Draped Table 8'L x 30"H.....	\$139.00	\$152.90	\$194.60	_____
_____	c12404630	4th Side Drape 6'L x 30"H.....	\$33.00	\$36.30	\$46.20	_____
_____	c12404830	4th Side Drape 8'L x 30"H.....	\$33.00	\$36.30	\$46.20	_____
_____	C130342	Draped Counter 3'L x 42"H...	\$128.75	\$141.65	\$180.25	_____
_____	C130442	Draped Counter 4'L x 42"H...	\$146.25	\$160.90	\$204.75	_____
_____	C130642	Draped Counter 6'L x 42"H...	\$153.50	\$168.85	\$214.90	_____
_____	C130842	Draped Counter 8'L x 42"H...	\$177.25	\$195.00	\$248.15	_____
_____	c12404642	4th Side Drape 6'L x 42"H.....	\$38.00	\$41.80	\$53.20	_____
_____	c12404842	4th Side Drape 8'L x 42"H.....	\$38.00	\$41.80	\$53.20	_____

Undraped Tables - Tables are 30" wide						
_____	C131330	Undraped Table 3'L x 30"H.....	\$43.25	\$47.60	\$60.55	_____
_____	C131430	Undraped Table 4'L x 30"H.....	\$50.00	\$55.00	\$70.00	_____
_____	C131630	Undraped Table 6'L x 30"H.....	\$59.75	\$65.75	\$83.65	_____
_____	C131830	Undraped Table 8'L x 30"H.....	\$69.00	\$75.90	\$96.60	_____
_____	C131342	Undraped Counter 3'L x 42"H.	\$62.00	\$68.20	\$86.80	_____
_____	C131442	Undraped Counter 4'L x 42"H.	\$69.00	\$75.90	\$96.60	_____
_____	C131642	Undraped Counter 6'L x 42"H.	\$81.50	\$89.65	\$114.10	_____
_____	C131842	Undraped Counter 8'L x 42"H.	\$88.75	\$97.65	\$124.25	_____

MISCELLANEOUS						
_____	C220134	Chrome Easel.....	\$45.50	\$50.05	\$63.70	_____
_____	220106	Corrugated Wastebasket.....	\$18.00	\$19.80	\$25.20	_____

Special Drape									
<input type="checkbox"/>	Black	<input type="checkbox"/>	Blue	<input type="checkbox"/>	Brown	<input type="checkbox"/>	Dark Green	<input type="checkbox"/>	Flax
<input type="checkbox"/>	Gold	<input type="checkbox"/>	Gray	<input type="checkbox"/>	Plum	<input type="checkbox"/>	Red	<input type="checkbox"/>	White

_____	12103	Special Drape 3'H (per ft.).....	\$18.25	\$20.10	\$25.55	_____
_____	12108	Special Drape 8'H (per ft.).....	\$21.25	\$23.40	\$29.75	_____

TOTAL COST		
Sub-Total _____	+ Tax (8.25%) _____	= _____

Remember to select a color for items with checkboxes.  
A color will be selected for you if not indicated.

FREEMAN furnishing essentials 2

Take advantage of the Online price  
by ordering at [www.freemanco.com/store](http://www.freemanco.com/store)  
before SEPTEMBER 16, 2015

# FREEMAN

9258 Park South View, Suite 100  
Houston, Texas 77051

Ph: 713-770-6750 • Fax: 469-621-5613  
FreemanHoustonES@freemanco.com

**ONLINE PRICE  
DISCOUNT PRICE  
DEADLINE DATE  
SEPTEMBER 16, 2015**

INCLUDE THE FREEMAN METHOD OF  
PAYMENT FORM WITH YOUR ORDER

**FREEMAN accessories**

NAME OF SHOW: UH CT BAUER COLLEGE OF BUSINESS CAREER FAIR / SEPT 25, 2015

COMPANY NAME \_\_\_\_\_ BOOTH #: \_\_\_\_\_

CONTACT NAME: \_\_\_\_\_ PHONE #: \_\_\_\_\_

E-MAIL ADDRESS \_\_\_\_\_

For Assistance, please call 713-770-6750 to speak with one of our experts.

For fast, easy ordering, go to [www.freemanco.com/store](http://www.freemanco.com/store)

## ACCESSORIES

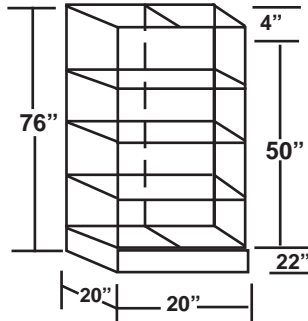

**Glass Tower Showcase - 1010200**

Comes with two doors that lock and three glass shelves.

1. Lessee will be responsible for any damages to display fixtures during the event.
2. There will be a replacement charge of \$10.00 on all lost keys.
3. Electrical hookup must be ordered through the Electrical order form included in your service manual.

**Straight Hook - 10201**



**Single Hook - 10203**



**"J" Hook-10206**



**Double Hook - 10204**

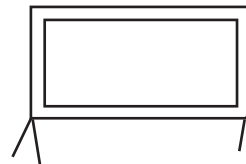

**10201484 - Bulletin Board**

4' x 8' Horizontal  
All boards are gray velcro and double sided.

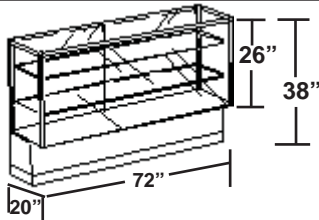

**101063 - 6'**

**STYLE #A FULL VISION CASE**, includes 1-8" and 1-10" glass shelves with adjustable brackets, 26" high front glass display section. 6' Showcase comes with light fixture and locks.

**15905 - Fish Bowl**

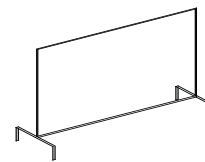

**10405 - Garment Rack**

### SHOWCASES

		Online Price	Discount Price	Standard Price	
_____	101063 Full Vision Case - 6'.....	425.00	467.50	595.00	_____
_____	1010200 Glass Tower Case .....	477.00	524.70	667.80	_____

### MISCELLANEOUS

		Online Price	Discount Price	Standard Price	
_____	10405 Garment Rack .....	105.00	115.50	147.00	_____
_____	15905 Fish Bowl.....	23.25	25.60	32.55	_____
_____	10201 2" Straight Hook (each).....	.30	.35	.40	_____
_____	10206 "J" Loop Hook (each).....	.30	.35	.40	_____
_____	10203 6" Single Hook (each).....	.30	.35	.40	_____
_____	10204 6" Double Hook (each).....	1.70	1.85	2.40	_____
_____	10201484 Bulletin Board.....	186.00	204.60	260.40	_____

Sub-Total \_\_\_\_\_ + Tax (8.25%) \_\_\_\_\_ = TOTAL \_\_\_\_\_

Take advantage of the Online price by ordering at [www.freemanco.com/store](http://www.freemanco.com/store) before **SEPTEMBER 16, 2015**